



MSP GN GM BH

Märkische Stanz-Partner



[führungssysteme]

[guidingsystems]

Stand / Revision Status 01.04.2022



Inhalt Katalog 1: Stanznormalien (D)

Content Catalogue 1: Standard die components (D)



Artikel Article	Best.-Nr. Order no.	Seite Page
A		
Aufwerferstifte, gehärtet, DIN 1530 A – ISO 6750	TH 750	TH.9
Auswerferstifte, DIN 1530 Form D	TH 751	TH.10

Ein „Klick“ auf Artikelbezeichnung, Bestell-Nummer oder Seite im vorangestellten Inhaltsverzeichnis bringt Sie zum gewünschten Artikel.

„Clicking“ on the Article name, the Order- or Page-no. in the main table of contents opens the corresponding article-page.

Inhalt

Content



	Schneidstempel	Punches	Best.-Nr. Order no.	Seite Page
	Schneidstempel DIN 9861, Form D, HSS	Punches DIN 9861, Form D, HSS	SE 775	SF.1 SF.2

Ein „Klick“ auf Foto, Artikelbezeichnung, Bestell-Nummer oder Seite im Inhaltsverzeichnis des Registers bringt Sie unmittelbar zum gewünschten Artikel im Katalog.

„Clicking“ on the Photo, the Article name, the Order- or Page-no. in any register's table of contents opens the corresponding article-page.



Ein „Klick“ auf das CAD-Logo bringt Sie zu den CAD-Daten des gewünschten Artikels im CADENAS-Downloadportal.



„Clicking“ on the CAD-logo leads you to the CAD-file(s) of the corresponding article within the Cadenas download-portal.



Ein „Klick“ auf das MAIL-Logo generiert eine an die Märkischen Stanz-Partner adressierte e-mail, mit der Normbezeichnung des gewünschten Artikels in der Betreffzeile.



„Clicking“ on the MAIL-logo generates an e-mail addressed to the Stanz-Partners, showing the requested article in the subject heading.







Ein „Klick“ auf das RETURN-Logo unten auf jeder Katalogseite bringt Sie zurück auf das Inhaltsverzeichnis des entsprechenden Registers.









„Clicking“ on the RETURN-logo at the bottom of each catalog-page opens that specific register's table of contents.













	Führungselemente, M-Line	Guidingelements, M-Line	Best.-Nr. Order no.	Seite Page
	Führungsbuchsen mit Bund, Kugelführung, M-Line, kurzer Bund	Leader pin bushings, with collar, ball bearing, M-Line, short headed	FS 357	FS.13
	Führungsbuchsen mit Bund, Kugelführung, M-Line, langer Bund	Leader pin bushings, with collar, ball bearing, M-Line, long headed	FS 353 FS 358	FS.13
	Führungsbuchsen mit Bund, Stahl/Bronze, M-Line, kurzer Bund	Leader pin bushings, with collar, steel/bronze, M-Line, short headed	FS 331	FS.4
	Führungsbuchsen mit Bund, Stahl/Bronze, M-Line, langer Bund	Leader pin bushings, with collar, steel/bronze, M-Line, long headed	FS 351 FS 355	FS.4
	Führungsbuchsen mit Bund, Stahlführung, M-Line, kurzer Bund RM-beschichtet	Leader pin bushings, with collar, steel, M-Line, short headed RM-coated	FS 330 RM	FS.3
	Führungsbuchsen mit Bund, Stahlführung, M-Line, langer Bund RM-beschichtet	Leader pin bushings, with collar, steel, M-Line, long headed RM-coated	FS 340 RM FS 350 RM	FS.3
	Führungsbuchsen mit Festschmierstoff-ringen, M-Line, kurzer Bund	Leader pin bushings with self lubricating graphite rings, M-Line, short headed	FS 375	FS.5
	Führungsbuchsen mit Festschmierstoff-ringen, M-Line, langer Bund	Leader pin bushings with self lubricating graphite rings, M-Line, long headed	FS 371 FS 374	FS.5
	Führungssäulen, zylindrisch, zum Einpressen, M-Line	Leader pins, cylindrical, for press fitting, M-Line	FS 320	FS.1
	Haltescheiben für Bundsäulen-befestigung	Holding discs	FS 398	FS.15
	Haltestücke	Holding clamps	FS 395 / A - D	FS.15
	Kugelkäfige aus Messing, M-Line	Ball cages, brass, M-Line	FS 325	FS.14
	Schnellwechsel-Führungssäulen mit Bund, M-Line	Quick change leader pins with collar, M-Line	FS 319	FS.2
	Wechselbuchsen-Systeme mit Säulen-zentrierung, glatt, mit HALCO	Modular System of interchangeable bushings with leader pin centering, straight, with HALCO	FS 380/1	FS.7
	Wechselbuchsen-Systeme mit Säulen-zentrierung, glatt, mit HALCO/Kugelführung	Modular System of interchangeable bushings with leader pin centering, straight, with HALCO/ball guide	FS 380/2	FS.8
	Wechselbuchsen-Systeme mit Säulen-zentrierung mit Bund, mit HALCO	Modular System of interchangeable bushings with leader pin centering with collar, with HALCO	FS 381/1	FS.9
	Wechselbuchsen-Systeme mit Säulen-zentrierung mit Bund, mit HALCO/Kugelführung	Modular System of interchangeable bushings with leader pin centering with collar, with HALCO/ball guide	FS 381/2	FS.10
	Wechselbuchsen-Systeme mit Säulen-zentrierung mit Flansch, mit HALCO	Modular System of interchangeable bushings with leader pin centering with flange, with HALCO	FS 382/1	FS.11
	Wechselbuchsen-Systeme mit Säulen-zentrierung mit Flansch, mit HALCO/Kugelführung	Modular System of interchangeable bushings with leader pin centering with flange, with HALCO/ball guide	FS 382/2	FS.12

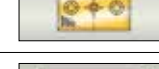
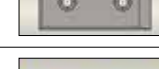
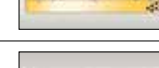

	Führungssäulen	Leader pins	Best.-Nr. Order no.	Seite Page
	<u>Führungssäulen für Großwerkzeuge nach DIN 9833</u>	<u>Leader pins for large dies, DIN 9833</u>	FS 410 FS 412	FS.18 FS.19
	<u>Führungssäulen, zylindrisch, zum Einpressen, nach DIN 9825</u>	<u>Leader pins, cylindrical, for press fitting, DIN 9825</u>	FS 420	FS.16
	<u>Schnellwechsel-Führungssäulen mit Bund</u>	<u>Quick change leader pins with collar</u>	FS 419	FS.17

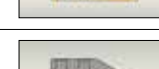
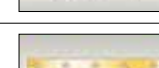



	Führungsbuchsen	Leader pin bushings	Best.-Nr. Order no.	Seite Page
	<u>Führungsbuchsen mit Bund, Bronze beschichtet, kurzer Bund</u>	<u>Leader pin bushings, with collar, bronze plated, short headed</u>	FS 631 FS 632	FS.23 FS.24
	<u>Führungsbuchsen mit Bund, Bronze beschichtet, langer Bund</u>	<u>Leader pin bushings, with collar, bronze plated, long headed</u>	FS 641, FS 651 FS 655	FS.23 FS.24
	<u>Führungsbuchsen mit Bund, Gleitschicht Sintermetall, kurzer Bund</u>	<u>Leader pin bushings, with collar, sinter-metal plated, short headed</u>	FS 731 FS 732	FS.21 FS.22
	<u>Führungsbuchsen mit Bund, Gleitschicht Sintermetall, langer Bund</u>	<u>Leader pin bushings, with collar, sinter-metal plated, long headed</u>	FS 741, FS 751 FS 755	FS.21 FS.22
	<u>Führungsbuchsen mit Bund, Kugelführung</u>	<u>Leader pin bushings, with collar, for ball bearing application</u>	FS 457, FS 458 FS 453	FS.25
	<u>Führungsbuchsen mit Bund, Stahlführung, kurzer Bund RM-beschichtet</u>	<u>Leader pin bushings, with collar, steel, short headed RM-coated</u>	FS 430 RM FS 439 RM	FS.20
	<u>Führungsbuchsen mit Bund, Stahlführung, langer Bund RM-beschichtet</u>	<u>Leader pin bushings, with collar, steel, long headed RM-coated</u>	FS 440 RM FS 450 RM	FS.20
	<u>Führungsbuchsen mit Festschmierstoff</u>	<u>Leader pin bushings with self lubricating graphite plugs</u>	FS 462	FS.34
	<u>Führungsbuchsen mit Festschmierstoff NAAMS</u>	<u>Leader pin bushings with self lubricating graphite plugs, NAAMS</u>	FS 461	FS.33
	<u>Führungsbuchsen mit Festschmierstoff nach DIN 9834 / ISO 9448</u>	<u>Leader pin bushings with self lubricating graphite plugs, DIN 9834 / ISO 9448</u>	FS 460	FS.31

	Kugelkäfige und Befestigungselemente	Ball cages and mounting elements	Best.-Nr. Order no.	Seite Page
	<u>Abgehängte Kugelkäfige</u>	<u>Ball cages with circlip</u>	FS 424	FS.27 FS.28
	<u>Befestigungselemente RA</u>	<u>Mounting elements RA</u>	FS 424 / RA	FS.30
	<u>Befestigungselemente SI</u>	<u>Mounting elements SI</u>	FS 424 / SI	FS.29
	<u>Befestigungselemente TR</u>	<u>Mounting elements TR</u>	FS 424 / TR	FS.29
	<u>Befestigungselemente VI</u>	<u>Mounting elements VI</u>	FS 424 / VI	FS.30
	<u>Kugelkäfige aus Messing</u>	<u>Ball cages, brass</u>	FS 425	FS.26

	Gleitplatten	Wear plates	Best.-Nr. Order no.	Seite Page
	<u>Führungslaschen, Stahl mit Festschmierstoff</u>	<u>Guide brackets, steel with self lubricating graphite plugs</u>	FS 509	FS.46
	<u>Gleitleisten VDI 3357 Bronze mit Festschmierstoff</u>	<u>Wear strips VDI 3357 with self lubricating graphite plugs</u>	FS 506	FS.43
	<u>Gleitplatten, Bronze mit Festschmierstoff, 5 mm dick</u>	<u>Wear plates, bronze with self lubricating graphite plugs, 5 mm thick</u>	FS 505	FS.42
	<u>Gleitplatten, Bronze mit Festschmierstoff, 10 mm dick</u>	<u>Wear plates, bronze with self lubricating graphite plugs, 10 mm thick</u>	FS 503 FS 504	FS.40 FS.41
	<u>Gleitplatten VDI 3357 Bronze mit Festschmierstoff, 12 mm dick</u>	<u>Wear plates VDI 3357 with self lubricating graphite plugs, 12 mm thick</u>	FS 502	FS.39
	<u>Gleitplatten VDI 3357 Bronze mit Festschmierstoff, 20 mm dick</u>	<u>Wear plates VDI 3357 with self lubricating graphite plugs, 20 mm thick</u>	FS 500	FS.37
	<u>Gleitplatten VDI 3357, Stahl, 20 mm dick</u>	<u>Wear plates VDI 3357, steel, 20 mm thick</u>	FS 501	FS.38
	<u>Prismenführungen, VDI 3357, Bronze mit Festschmierstoff</u>	<u>„V“ drivers, VDI 3357, bronze with self lubricating graphite plugs</u>	FS 526	FS.50
	<u>Prismenführungen, VDI 3357, Stahl</u>	<u>„V“ drivers, VDI 3357, steel</u>	FS 524	FS.49
	<u>Überlaufkeile, VDI 3357, Bronze mit Festschmierstoff</u>	<u>Cam dwells, VDI 3357, bronze with self lubricating graphite plugs</u>	FS 507	FS.44
	<u>Überlaufkeile, VDI 3357, Stahl</u>	<u>Cam dwells, VDI 3357, steel</u>	FS 508	FS.45
	<u>Winkelleisten, Bronze mit Festschmierstoff</u>	<u>„L“ shaped wear plates, bronze with self lubricating graphite plugs</u>	FS 510	FS.47



	Gleitplatten	Wear plates	Best.-Nr. Order no.	Seite Page
	Winkelleisten, VDI 3357, Bronze mit Festschmierstoff	„L“ shaped wear plates, VDI 3357, bronze with self lubricating graphite plugs	FS 511	FS.48

	Zubehör Bereich Führungssysteme	Elements product line „guiding systems“	Best.-Nr. Order no.	Seite Page
	Haltescheiben für Bundsäulenbefestigung	Holding discs	FS 958	FS.36
	Haltestücke für Führungsbuchsen mit Festschmierstoff n.DIN 9834 / ISO 9448	Holding clamps for bronze leader pin bushings with selflubricating graphite plugs, DIN 9834 / ISO 9448	FS 460 HS	FS.32
	Haltestücke für Säulen- und Buchsenbefestigung	Holding clamps for holding leader pins and -bushings	FS 955	FS.35



FS 320

Mat.: 1.7131 / 61 - 63 HRC

Mat.: 1.7131 / 61 - 63 HRC

 FS 320 / 25 x 200

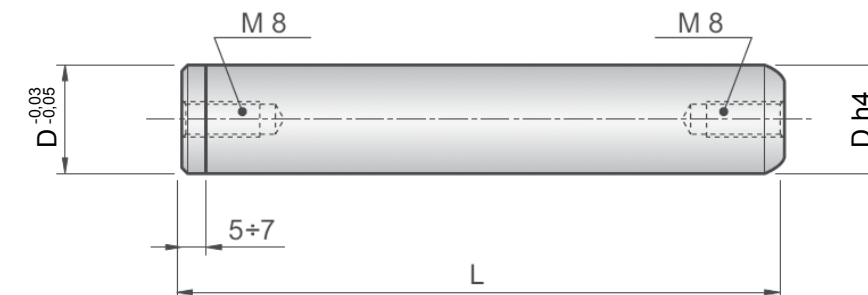

D	L																	
	100	112	125	140	160	180	200	224	250	280	315	355	400	450	500	600	700	800
19-20	•	•	•	•	•	•	•	•	•									
24-25			•	•	•	•	•	•	•	•	•	•	•	•	•			
30-32			•	•	•	•	•	•	•	•	•	•	•	•	•			
38-40					•	•	•	•	•	•	•	•	•	•	•			
48-50							•	•	•	•	•	•	•	•	•			
60-63								•	•	•	•	•	•	•	•			
80									•	•	•	•	•	•	•	•	•	•



FS 319

Mat.: 1.7131 / 61 - 63 HRC

Mat.: 1.7131 / 61 - 63 HRC

FS 319 / 25 x 160

Lieferumfang:

- 3 Halteklammern mit Schrauben alternativ, wenn angegeben:
- 1 Haltescheibe **FS 398** mit Schraube

Included:

- 3 holding clamps with screws alternatively, if specified:
- 1 mount disc **FS 398** with screw

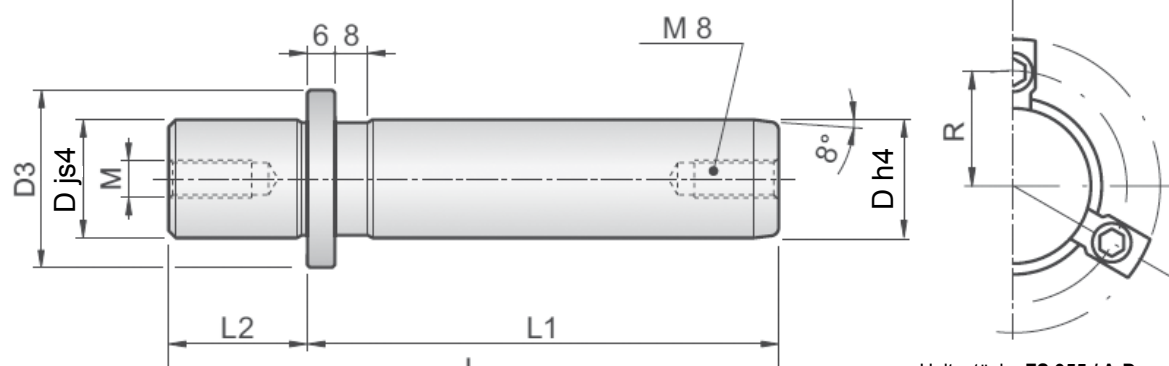

Haltestücke **FS 955 / A-D** und Haltescheiben **FS 398** siehe Seite FS.15. / Holding clamps **FS 955 / A-D** and holding disks **FS 398** see page FS.15.



D	D3	M	R	L2
19-20	25	M8	18,0	23
24-25	32	M8	21,5	30
30-32	40	M8	25,5	37
38-40	50	M8	30,5	37
48-50	63	M8	37,0	47
60-63	80	M8	45,5	47
80	95	M12	53,0	60

D	L1												
	100	112	125	140	160	180	200	224	250	280	315	355	400
19-20	•	•	•	•	•	•	•						
24-25	•	•	•	•	•	•	•	•	•				
30-32		•	•	•	•	•	•	•	•	•	•		
38-40			•	•	•	•	•	•	•	•	•	•	
48-50				•	•	•	•	•	•	•	•	•	•
60-63					•	•	•	•	•	•	•	•	•
80						•	•	•	•	•	•	•	•

mit langem Bund/long-headed style
FS 340 ... RM
FS 350 ... RM

Mat.: 1.7131 / 61 - 63 HRC
RM-beschichtet (selbstschmierend)

Mat.: 1.7131 / 61 - 63 HRC
RM-coated (self lubricating)

FS 340 / 25 x 59 / RM

Lieferumfang:

- 3 Halteklammern mit Schrauben

Included:

- 3 holding clamps with screws

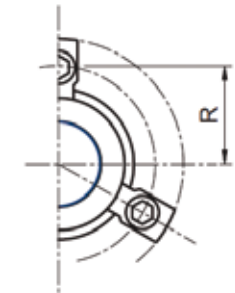
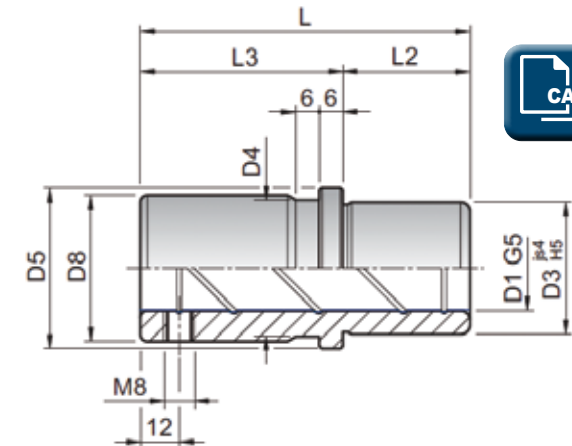

Haltestücke **FS 955 / A-D** siehe Seite FS.15. / Holding clamps **FS 955 / A-D** see page FS.15.

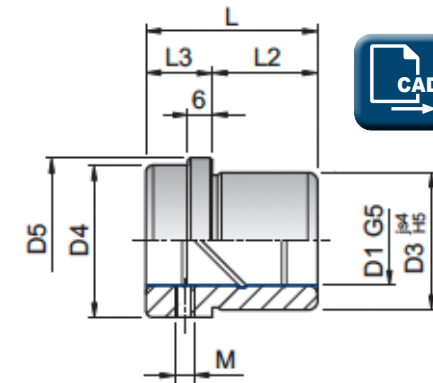

mit kurzem Bund/short-headed style
FS 330 ... RM



D1	D3	D4	D5	D8	Artikelnummer Article number	R	L	L2	L3
19-20	32	32	40	-	FS 330 ... RM	26	35	23	12
19-20	32	32	40	39	FS 340 ... RM	26	43	23	20
19-20	32	32	40	39	FS 350 ... RM	26	59	23	36
24-25	40	40	48	-	FS 330 ... RM	30	35	23	12
24-25	40	40	48	46	FS 340 ... RM	30	59	23	36
24-25	40	40	48	46	FS 350 ... RM	30	79	23	56
30-32	48	48	56	-	FS 330 ... RM	33,5	42	30	12
30-32	48	48	56	53	FS 340 ... RM	33,5	75	30	45
30-32	48	48	56	53	FS 350 ... RM	33,5	93	30	63
38-40	58	58	66	-	FS 330 ... RM	38,5	52	37	15
38-40	58	58	66	63	FS 340 ... RM	38,5	82	37	45
38-40	58	58	66	63	FS 350 ... RM	38,5	108	37	71
48-50	70	70	80	-	FS 330 ... RM	45,5	65	47	18
48-50	70	70	80	77	FS 340 ... RM	45,5	97	47	50
48-50	70	70	80	77	FS 350 ... RM	45,5	127	47	80
60-63	85	85	95	-	FS 330 ... RM	53	80	60	20
60-63	85	85	95	92	FS 340 ... RM	53	116	60	56
60-63	85	85	95	92	FS 350 ... RM	53	150	60	90

Führungsbuchsen mit Bund, Stahl/Bronze, M-Line

Leader pin bushings with collar, steel/bronze, M-Line

FÜHRUNGSSYSTEME / GUIDINGSYSTEMS



mit langem Bund/long-headed style

FS 351
FS 355

Mat.: 1.7131 + Bronze
Härte: 61 - 63 HRC

Mat.: 1.7131 + bronze
Hardness: 61 - 63 HRC

FS 331 / 25 x 35

Lieferumfang:
• 3 Halteklammern mit Schrauben

Included:
• 3 holding clamps with screws

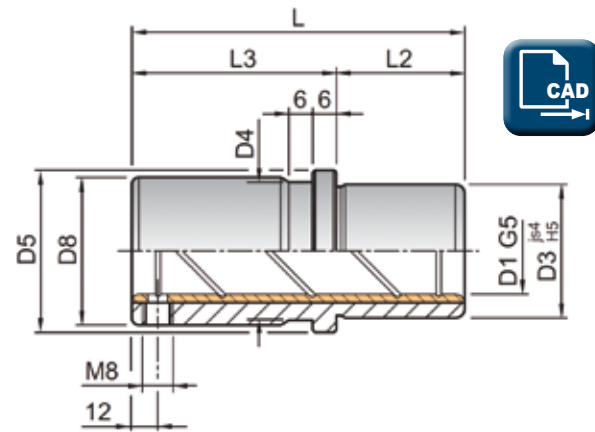

Haltestücke **FS 955 / A-D**
siehe Seite FS.15. /
Holding clamps **FS 955 / A-D**
see page FS.15.

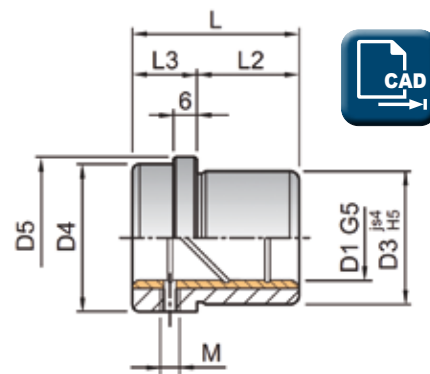

Führungsbuchsen können auch
RM-beschichtet werden /
Leader pin bushings can be
delivered RM-coated.

mit kurzem Bund/short-headed style
FS 331



D1	D3	D4	D5	D8	Artikelnummer Article number	R	L	L2	L3
19-20	32	32	40	-	FS 331	26	35	23	12
19-20	32	32	40	39	FS 351	26	43	23	20
19-20	32	32	40	39	FS 355	26	59	23	36
24-25	40	40	48	-	FS 331	30	35	23	12
24-25	40	40	48	46	FS 351	30	59	23	36
24-25	40	40	48	46	FS 355	30	79	23	56
30-32	48	48	56	-	FS 331	33,5	42	30	12
30-32	48	48	56	53	FS 351	33,5	75	30	45
30-32	48	48	56	53	FS 355	33,5	93	30	63
38-40	58	58	66	-	FS 331	38,5	52	37	15
38-40	58	58	66	63	FS 351	38,5	82	37	45
38-40	58	58	66	63	FS 355	38,5	108	37	71
48-50	70	70	80	-	FS 331	45,5	65	47	18
48-50	70	70	80	77	FS 351	45,5	97	47	50
48-50	70	70	80	77	FS 355	45,5	127	47	80
60-63	85	85	95	-	FS 331	53	80	60	20
60-63	85	85	95	92	FS 351	53	116	60	56
60-63	85	85	95	92	FS 355	53	150	60	90

Führungsbuchsen mit Festschmierstoffringen, M-Line

Leader pin bushes with self lubricating graphite rings, M-Line

FÜHRUNGSSYSTEME / GUIDINGSYSTEMS



mit langem Bund/long-headed style

FS 371
FS 374

Mat.: Bronze-Graphit

Mat.: Bronze-graphite

FS 371 / 019x59

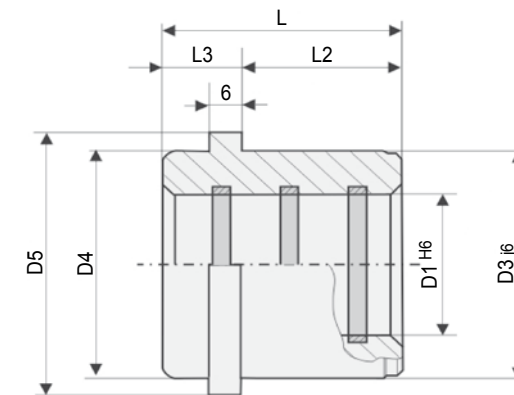
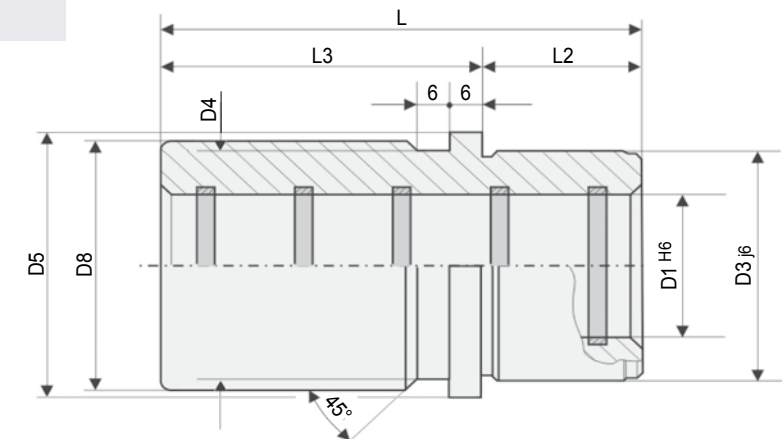

mit kurzem Bund/short-headed style
FS 375



D1	D3	D4	D5	D8	Artikelnummer Article number	L	L2	L3
019-020	32	32	40	-	FS 375	35	23	12
019-020	32	32	40	39	FS 371	59	23	36
019-020	32	32	40	39	FS 374	43	23	20
024-025	40	40	48	-	FS 375	35	23	12
024-025	40	40	48	46	FS 371	79	23	56
024-025	40	40	48	46	FS 374	59	23	36
030-032	48	48	56	-	FS 375	42	30	12
030-032	48	48	56	53	FS 371	93	30	63
030-032	48	48	56	53	FS 374	75	30	45
038-040	58	58	66	-	FS 375	52	37	15
038-040	58	58	66	63	FS 371	108	37	71
038-040	58	58	66	63	FS 374	82	37	45
048-050	70	70	80	-	FS 375	65	47	18
048-050	70	70	80	77	FS 371	127	47	80
048-050	70	70	80	77	FS 374	97	47	50
060-063	85	85	95	-	FS 375	80	60	20
060-063	85	85	95	92	FS 371	150	60	90
060-063	85	85	95	92	FS 374	116	60	56
080	105	105	118	-	FS 375	80	60	20
080	105	105	118	115	FS 371	150	60	90
080	105	105	118	115	FS 374	120	60	60

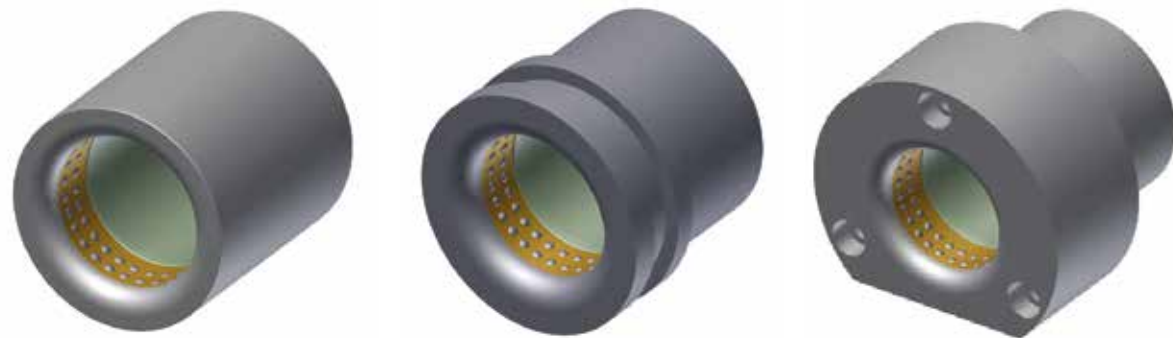

Beim Wechselbuchsen (WeBu) - System handelt es sich um die Paarung einer Stahl-Aufnahmebuchse (die über eine spezielle Geometrie zur automatischen Säulenzentrierung verfügt) mit entweder einer HALCO-Führungsbuchse, einer Kugelführung, oder einer Kombination dieser beiden. Die Buchsen sind miteinander austauschbar. Bei einer reinen Kugelführung empfehlen wir eine gehärtete Aufnahmebuchse.

Vorteil der „Wechselbarkeit“:

- Flexibilität in der Führungsauswahl

Vorteile der Säulenzentrierung:

- Das Zentrieren der Säulen in die Gleitführungen erfolgt automatisch, einfach und ohne Beschädigung. Ein Verkanten der Führungsplatte durch eine bzw. mehrere Führungseinheiten wird vermieden.
- Die Demontage und Montage von Werkzeugen und Vorrichtungen kann schneller ausgeführt werden, die Lebensdauer wird erhöht.

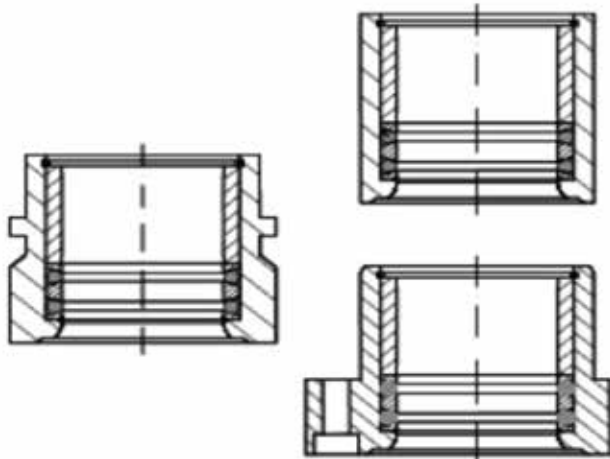
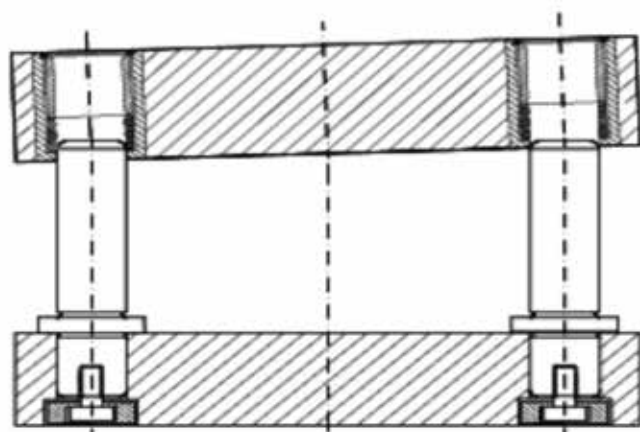

The modular bushings (ModBu) - system is the combination of a receiving steel bushing (with a special geometry for automatic leader pin centering) with either a HALCO guide bushing, a ball guide or a combination of both, all of them being interchangeable. For the complete ball guide option, we recommend a hardened receiving bushing.

Advantage of the „Interchangeability“:

- Flexibility in choosing guiding option

Advantages of the leader pin centering:

- The self-centering of the leader pins into the guide bushings happens automatically, simple and without damage ... and thereby avoids a tilting of the guide plate due to misalignment of one or more guiding units.
- The disassembly and assembly of dies, tools and fixtures can be carried out more quickly, the service life increases.

FS 380/1

Führungselement:
HALCO Wechselbuchse
Mat.: Hochleistungs-Aluminium
Oberflächenhärte: ~ 70 HRc
wartungsfrei

Stahl-Aufnahmebuchse:
~ DIN 9831 / ISO 9448
Mat.: 42CrMo4
Klebspalt: min. 0,05 mm,
Einpressen vermeiden

Guiding element:
HALCO interchangeable bushing
Mat.: high-performance Aluminum
Surface hardness: ~ 70 HRc
maintenance-free

Receiving steel bushing:
~ DIN 9831 / ISO 9448
Mat.: 42CrMo4
Adhesive gap : 0,05 mm,
Avoid pressing in

FS 380/1 / 32 x 60

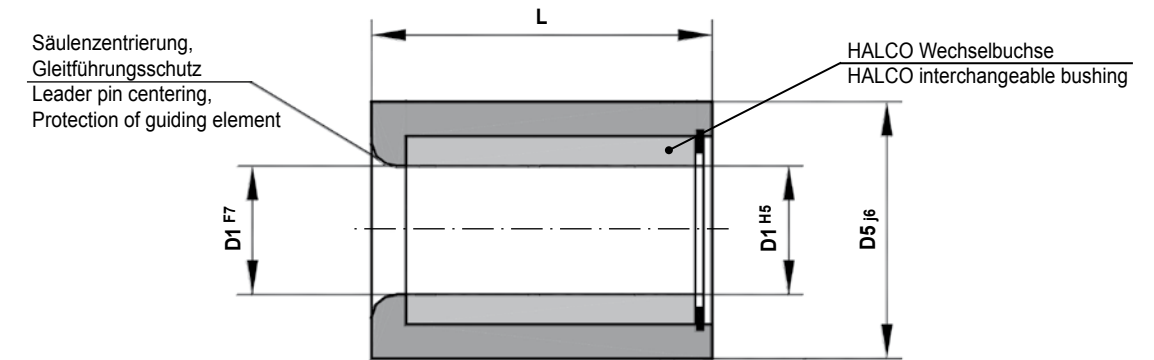

D1	L	D5
19-20	30	32
19-20	37	32
19-20	47	32
19-20	60	32
24-25	37	40
24-25	47	40
24-25	60	40
24-25	77	40
30-32	47	48
30-32	60	48
30-32	77	48
30-32	95	48
38-40	47	58
38-40	60	58

D1	L	D5
38-40	77	58
38-40	95	58
38-40	120	58
48-50	47	70
48-50	60	70
48-50	77	70
48-50	95	70
48-50	120	70
60-63	77	85
60-63	95	85
60-63	120	85
80	120	105
80	135	105

FS 380/2

Kombi-Führungselement:
Kugelführungsring zur Unterstützung der Säulenzentrierung kombiniert mit HALCO-Wechselbuchse
Mat. Hochleistungs-Aluminium
Oberflächenhärte = ~70 HRC
wartungsfrei

Stahl-Aufnahmebuchse:
~ DIN 9831 / ISO 9448
Mat.: 42CrMo4
Klebspalt: min. 0,05 mm,
Einpressen vermeiden

Combined guide element:
Ball guide ring for supporting the leader pin centering, combined with HALCO interchangeable bushing.
Mat. High performance aluminum
Surface hardness = ~ 70 HRC
maintenance-free

Receiving steel bushing:
~ DIN 9831 / ISO 9448
Mat.: 42CrMo4
Adhesive gap : 0,05 mm,
Avoid pressing in

FS 380/2 / 30 x 77

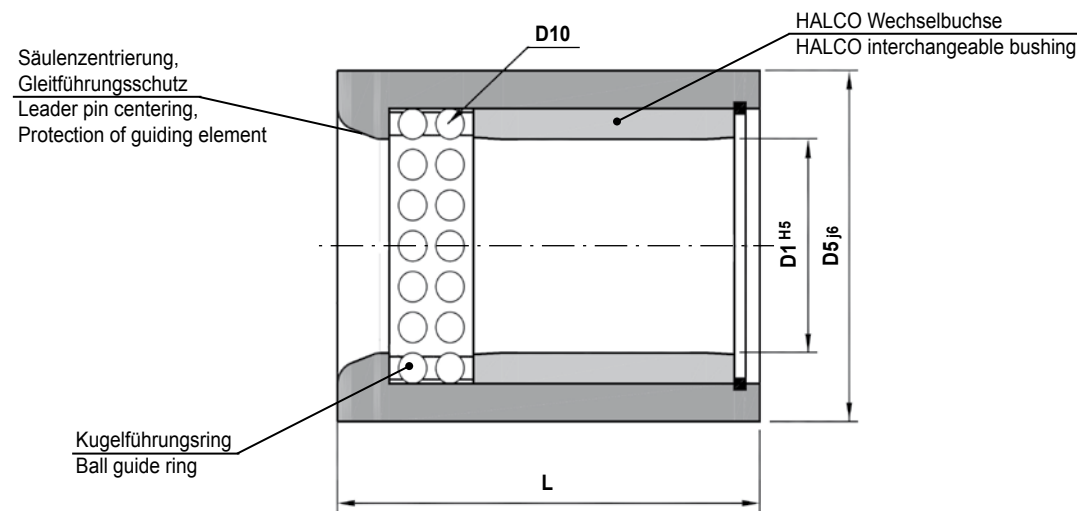

D1	L	D5	D10
19	60	32	3,5
20	60	32	3,0
24	60	40	3,5
24	77	40	3,5
25	60	40	3,0
25	77	40	3,0
30	60	48	5,0
30	77	48	5,0
30	95	48	5,0
32	60	48	4,0
32	77	48	4,0
32	95	48	4,0
38	60	58	5,0
38	77	58	5,0
38	95	58	5,0
38	120	58	5,0
40	60	58	4,0

D1	L	D5	D10
40	77	58	4,0
40	95	58	4,0
40	120	58	4,0
48	77	70	6,0
48	95	70	6,0
48	120	70	6,0
50	77	70	5,0
50	95	70	5,0
50	120	70	5,0
60	77	85	6,5
60	95	85	6,5
60	120	85	6,5
63	77	85	5,0
63	95	85	5,0
63	120	85	5,0
80	120	105	6,0
80	135	105	6,0

FS 381/1

Führungselement:
HALCO Wechselbuchse
Mat. Hochleistungs-Aluminium
Oberflächenhärte:~ 70 HRC
wartungsfrei

Stahl-Aufnahmebuchse:
~ DIN 9831 / ISO 9448
Mat.: 42CrMo4
Toleranz der Aufnahmebohrung: H6
Einpressen vermeiden
Haltestücke gehören zum Lieferumfang!

Guiding element:
HALCO interchangeable bushing
Mat.: high-performance Aluminum
Surface hardness: ~ 70 HRC
maintenance-free

Receiving steel bushing:
~ DIN 9831 / ISO 9448
Mat.: 42CrMo4
Tolerance to be bored: H6
Avoid pressing in
Holding clamps included

FS 381/1 / 30 x 77

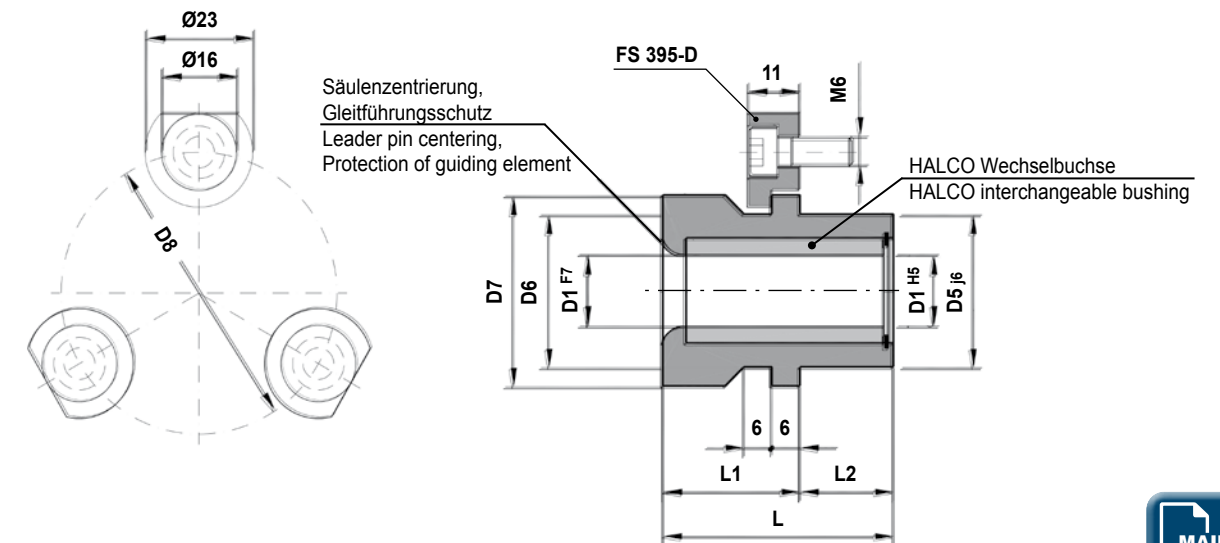

D1	L	D5	D6	D7	D8	L1	L2
19-20	37	32	32	40	59	14	23
19-20	47	32	32	40	59	24	23
19-20	60	32	32	40	59	37	23
24-25	47	40	40	48	65	24	23
24-25	60	40	40	48	65	37	23
24-25	77	40	40	48	65	54	23
30-32	60	48	48	56	73	30	30
30-32	77	48	48	56	73	47	30
30-32	95	48	48	56	73	65	30
38-40	60	58	58	66	83	24	36
38-40	77	58	58	66	83	41	36
38-40	95	58	58	66	83	59	36
38-40	120	58	58	66	83	84	36
48-50	77	70	70	80	97	31	46
48-50	95	70	70	80	97	49	46
48-50	120	70	70	80	97	74	46
60-63	77	85	85	95	112	21	56
60-63	95	85	85	95	112	39	56
60-63	120	85	85	95	112	64	56
80	120	105	105	118	135	64	56
80	135	105	105	118	135	79	56

FS 381/2

Kombi-Führungselement:
Kugelführungsring zur Unterstützung der Säulenzentrierung kombiniert mit HALCO-Wechselbuchse
Mat. Hochleistungs-Aluminium
Oberflächenhärte = ~70 HRC
wartungsfrei

Stahl-Aufnahmebuchse:
~ DIN 9831 / ISO 9448
Mat.: 42CrMo4
Toleranz der Aufnahmebohrung: H6
Einpressen vermeiden
Haltestücke gehören zum Lieferumfang!

Combined guide element:
Ball guide ring for supporting the leader pin centering, combined with HALCO interchangeable bushing.
Mat. High performance aluminum
Surface hardness = ~ 70 HRC
maintenance-free

Receiving steel bushing:
~ DIN 9831 / ISO 9448
Mat.: 42CrMo4
Tolerance to be bored: H6
Avoid pressing in
Holding clamps included

FS 381/2 / 48 x 120

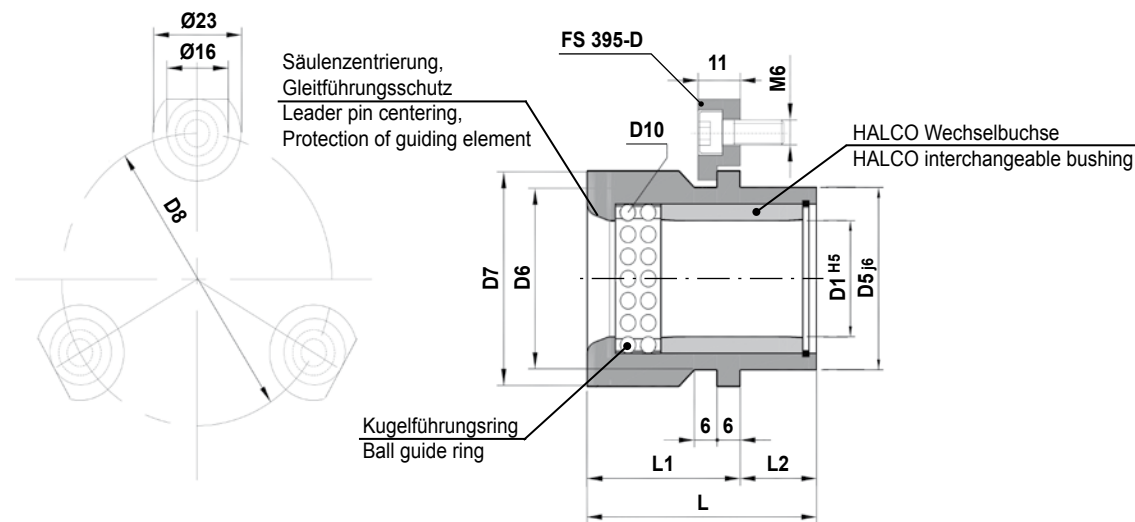

D1	L	D5	D6	D7	D8	L1	L2	D10
19-20	60	32	32	40	59	37	23	3,5-3,0
24-25	60	40	40	48	65	37	23	3,5-3,0
24-25	77	40	40	48	65	54	23	3,5-3,0
30-32	60	48	48	56	73	30	30	5,0-4,0
30-32	77	48	48	56	73	47	30	5,0-4,0
30-32	95	48	48	56	73	65	30	5,0-4,0
38-40	60	58	58	66	83	24	36	5,0-4,0
38-40	77	58	58	66	83	41	36	5,0-4,0
38-40	95	58	58	66	83	59	36	5,0-4,0
38-40	120	58	58	66	83	84	36	5,0-4,0
48-50	77	70	70	80	97	31	46	6,0-5,0
48-50	95	70	70	80	97	49	46	6,0-5,0
48-50	120	70	70	80	97	74	46	6,0-5,0
60-63	77	85	85	95	112	21	56	6,5-5,0
60-63	95	85	85	95	112	39	56	6,5-5,0
60-63	120	85	85	95	112	64	56	6,5-5,0
80	120	105	105	118	135	64	56	6,0
80	135	105	105	118	135	79	56	6,0



FS 382/1

Führungselement:
HALCO Wechselbuchse
Mat. Hochleistungs-Aluminium
Oberflächenhärte: ~ 70 HRC
wartungsfrei

Stahl-Aufnahmebuchse:
~ DIN 9831 / ISO 9448
Mat.: 42CrMo4
Toleranz der Aufnahmebohrung: H6
Einpressen vermeiden
Schrauben bitte gesondert bestellen.

Guiding element:
HALCO interchangeable bushing
Mat.: high-performance Aluminum
Surface hardness: ~ 70 HRc
maintenance-free

Receiving steel bushing:
~ DIN 9831 / ISO 9448
Mat.: 42CrMo4
Tolerance to be bored: H6
Avoid pressing in
Screws to be ordered separately.

FS 382/1 / 40 x 47

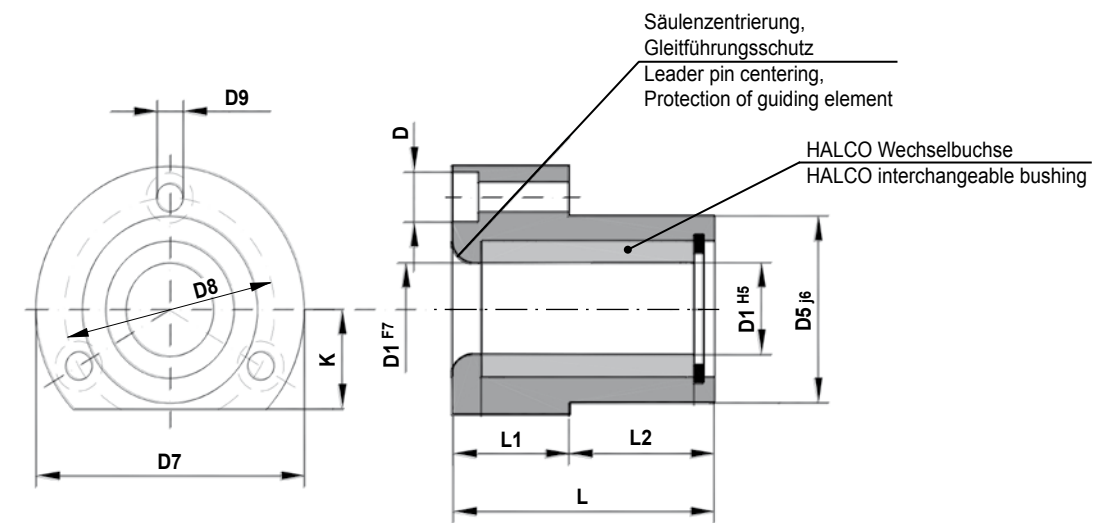

D1	L	D	D5	D7	D8	D9	L1	L2	K
19-20	37	8	32	52	40	4,5	14	23	18
19-20	60	8	32	52	40	4,5	24	36	18
24-25	37	9,5	40	63	50	5,5	14	23	23
24-25	47	9,5	40	63	50	5,5	24	23	23
24-25	60	9,5	40	63	50	5,5	30	30	23
30-32	37	9,5	48	72	58	5,5	14	23	28
30-32	60	9,5	48	72	58	5,5	24	36	28
30-32	77	9,5	48	72	58	5,5	31	46	28
38-40	47	11	58	85	70	6,6	17	30	33
38-40	60	11	58	85	70	6,6	24	36	33
38-40	77	11	58	85	70	6,6	31	46	33
48-50	60	14	70	104	86	9	24	36	38
48-50	77	14	70	104	86	9	31	46	38
48-50	95	14	70	104	86	9	49	46	38
48-50	120	14	70	104	86	9	64	56	38
60-63	95	14	85	120	100	9	49	46	46
60-63	120	14	85	120	100	9	64	56	46
80	120	18	105	148	125	11	64	56	56
80	135	18	105	148	125	11	59	76	56





FS 382/2

Kombi-Führungselement:
Kugelführungsring zur Unterstützung der Säulenzentrierung kombiniert mit HALCO-Wechselbuchse
Mat. Hochleistungs-Aluminium
Oberflächenhärte = ~70 HRC
wartungsfrei

Combined guide element:
Ball guide ring for supporting the leader pin centering, combined with HALCO interchangeable bushing.
Mat. High performance aluminum
Surface hardness = ~ 70 HRC
maintenance-free

FS 382/2 / 19 x 60

Stahl-Aufnahmebuchse:
~ DIN 9831 / ISO 9448
Mat.: 42CrMo4
Toleranz der Aufnahmebohrung: H6
Einpressen vermeiden
Schrauben bitte gesondert bestellen.

Receiving steel bushing:
~ DIN 9831 / ISO 9448
Mat.: 42CrMo4
Tolerance to be bored: H6
Avoid pressing in
Screws to be ordered separately.

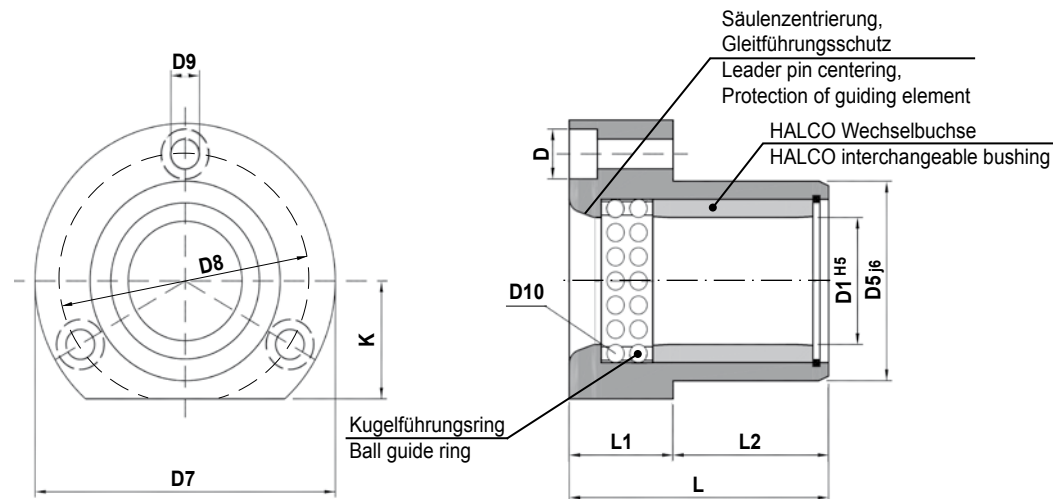

D1	L	D5	D7	D8	D9	L1	L2	K	D10
19-20	60	32	52	40	4,5	24	36	18	3,5-3,0
24-25	60	40	63	50	5,5	30	30	23	3,5-3,0
30-32	60	48	72	58	5,5	24	36	28	5,0-4,0
30-32	77	48	72	58	5,5	31	46	28	5,0-4,0
38-40	60	58	85	70	6,6	24	36	33	5,0-4,0
38-40	77	58	85	70	6,6	31	46	33	5,0-4,0
48-50	77	70	104	86	9	31	46	38	6,0-5,0
48-50	95	70	104	86	9	49	46	38	6,0-5,0
48-50	120	70	104	86	9	64	56	38	6,0-5,0
60-63	95	85	120	100	9	49	46	46	6,5-5,0
60-63	120	85	120	100	9	64	56	46	6,5-5,0
80	120	105	148	125	11	64	56	56	6,0
80	135	105	148	125	11	59	76	56	6,0



mit langem Bund/long-headed style

Mat.: 1.7131 / 61 - 63 HRC

Mat.: 1.7131 / 61 - 63 HRC

FS 358 / 25 x 59

**FS 358
FS 353**

Lieferumfang:
• 3 Halteklammern mit Schrauben

Included:
• 3 holding clamps with screws

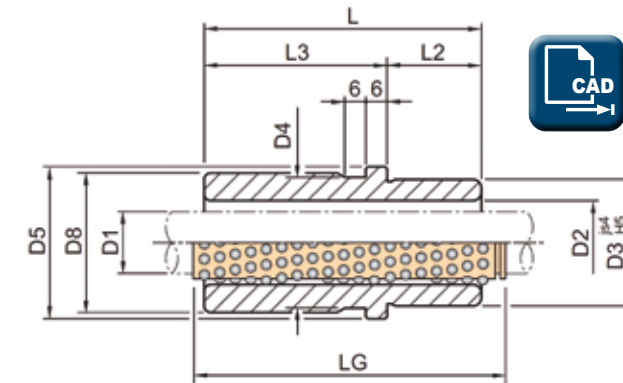

Haltestücke **FS 955 / A-D**
siehe Seite FS.15. /
Holding clamps **FS 955 / A-D**
see page FS.15.

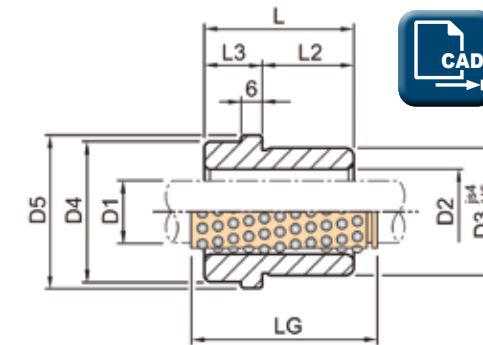

Führungsbuchsen können auch
RM-beschichtet werden /
Leader pin bushings can be
delivered RM-coated.

mit kurzem Bund/short-headed style

FS 357



D1	D2	D3	D4	D5	D8	Artikelnummer Article number	R	L	L2	L3	Vorschlag Proposal LG
19-20	25-26	32	32	40	-	FS 357	26	35	23	12	45
19-20	25-26	32	32	40	39	FS 358	26	43	23	20	56
19-20	25-26	32	32	40	39	FS 353	26	59	23	36	71
24-25	30-31	40	40	48	-	FS 357	30	35	23	12	45
24-25	30-31	40	40	48	46	FS 358	30	59	23	36	71
24-25	30-31	40	40	48	46	FS 353	30	79	23	56	95
30-32	38-40	48	48	56	-	FS 357	33,5	42	30	12	56
30-32	38-40	48	48	56	53	FS 358	33,5	75	30	45	95
30-32	38-40	48	48	56	53	FS 353	33,5	93	30	63	120
38-40	46-48	58	58	66	-	FS 357	38,5	52	37	15	63
38-40	46-48	58	58	66	63	FS 358	38,5	82	37	45	105
38-40	46-48	58	58	66	63	FS 353	38,5	108	37	71	120
48-50	56-58	70	70	80	-	FS 357	45,5	65	47	18	80
48-50	56-58	70	70	80	77	FS 358	45,5	97	47	50	120
48-50	56-58	70	70	80	77	FS 353	45,5	127	47	80	140
60-63	68-71	85	85	95	-	FS 357	53	80	60	20	95
60-63	68-71	85	85	95	92	FS 358	53	116	60	56	140
60-63	68-71	85	85	95	92	FS 353	53	150	60	90	160
80	92	105	105	118	-	FS 357	64,5	80	60	20	120
80	92	105	105	118	115	FS 358	64,5	120	60	60	140
80	92	105	105	118	115	FS 353	64,5	150	60	90	160

Kugelkäfige aus Messing, M-Line

Ball cages, brass, M-Line

FÜHRUNGSSYSTEME / GUIDINGSYSTEMS



FS 325

Mat.: Messing
Stahlkugeln: Güteklasse AAA

Mat.: Brass
Steel balls, grade AAA

FS 325 / 25 x 71

Sicherungsring im Lieferumfang enthalten.

Safety ring included

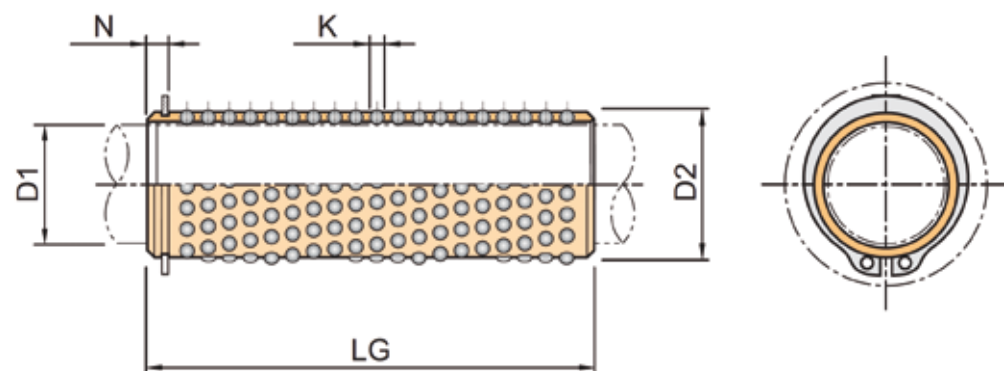

D1	LG															D2	K	N
	40	45	50	56	63	71	80	95	105	120	140	160	180	200	240			
19		•		•		•	•	•								25	3	2,9
20		•		•		•	•	•								26	3	2,9
24	•	•		•		•	•	•		•						30	3	3,2
25	•	•		•		•	•	•		•						31	3	3,2
30	•	•	•	•		•	•	•	•	•	•	•				38	4	3,95
32	•	•	•	•		•	•	•	•	•	•	•				40	4	3,95
38		•	•	•	•		•	•	•	•	•	•	•	•	•	46	4	3,95
40		•	•	•	•		•	•	•	•	•	•	•	•	•	48	4	3,95
48			•	•	•		•	•	•	•	•	•	•	•	•	56	4	4,25
50			•	•	•		•	•	•	•	•	•	•	•	•	58	4	4,25
60							•	•	•	•	•	•	•	•	•	68	4	4,75
63							•	•	•	•	•	•	•	•	•	71	4	4,75
80										•	•	•	•	•	•	92	6	6,15

Haltestücke / Haltescheiben, M-Line

Holding clamps / Holding discs, M-Line

FÜHRUNGSSYSTEME / GUIDINGSYSTEMS



FS 395 / A - D

FS 395 / A für Ø 19-20, 24-25
FS 395 / B für Ø 19-20, 24-25, 30-32, 38-40, 48-50, 60-63, 80
FS 395 / C für Ø 30-32, 38-40, 48-50, 60-63, 80

FS 395 / A für Ø 19-20, 24-25
FS 395 / B für Ø 19-20, 24-25, 30-32, 38-40, 48-50, 60-63, 80
FS 395 / C für Ø 30-32, 38-40, 48-50, 60-63, 80

FS 395 / A

Haltestücke werden mit Schrauben geliefert.

Holding clamps include screws.

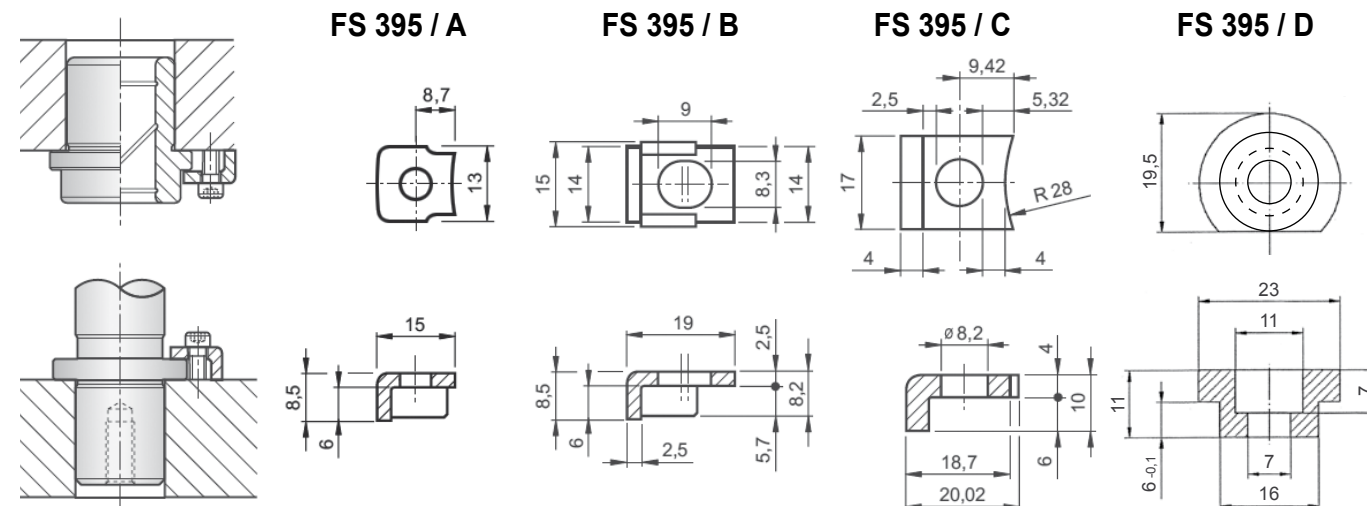

FS 398

Mat.: C 40, brüniert
Scheibe wird mit Schraube befestigt

Mat.: C 40, gunmetal-finished
Mount disc with screw.

FS 398 / 1

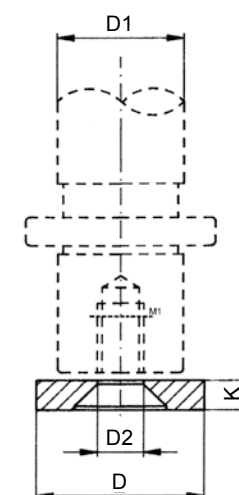

Ausführung Style	D1	D	K	D2
1	19-20	25	6	8,5
2	24-25	32	6	8,5
3	30-32	40	6	8,5
4	38-40	50	6	8,5
5	48-50	60	6	8,5
6	60-63	70	6	8,5
7	80	93	12	12,5

FS 420

Mat.: 1.5732 / 61 - 63 HRC

Mat.: 1.5732 / 61 - 63 HRC

FS 420 / 24 x 200

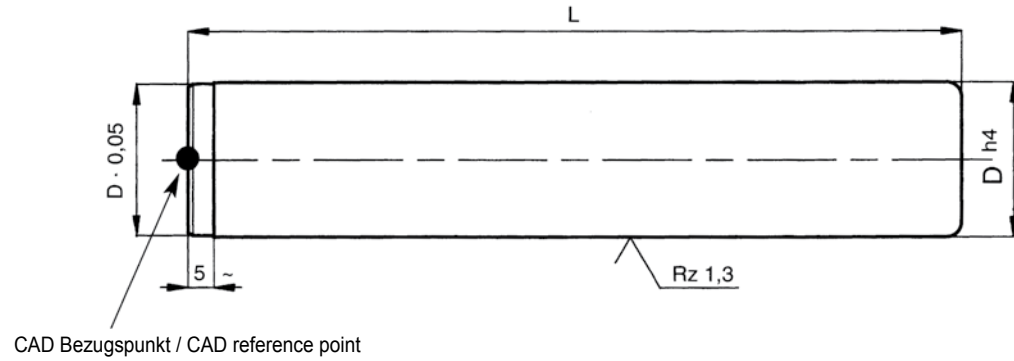

D	L																Aufnahmebohrung Mounting hole R7							
	120	130	140	150	160	170	180	190	200	210	220	230	240	250	260	270		280	300	320	350	360	400	
18-19	•	•	•	•	•	•	•	•	•															-0,020 -0,041
24-25			•	•	•	•	•	•	•	•	•	•	•	•	•	•	•	•						-0,020 -0,041
30-32			•	•	•	•	•	•	•	•	•	•	•	•	•	•	•	•						-0,025 -0,050
40-42						•	•	•	•	•	•	•	•	•	•	•	•	•	•					-0,025 -0,050
50-52							•	•	•	•	•	•	•	•	•	•	•	•	•	•				-0,030 -0,060
63									•	•	•	•	•	•	•	•	•	•	•	•				-0,030 -0,060
80																		•	•	•	•	•		-0,032 -0,062

FS 419

Mat.: 1.5732 / 61 - 63 HRC

Mat.: 1.5732 / 61 - 63 HRC

FS 419 / 25 x 160

Lieferumfang:
• 3 Halteklammern mit Schrauben
(D ≤ 80 mm)

Included:
• 3 holding clamps with screws
(D ≤ 80 mm)

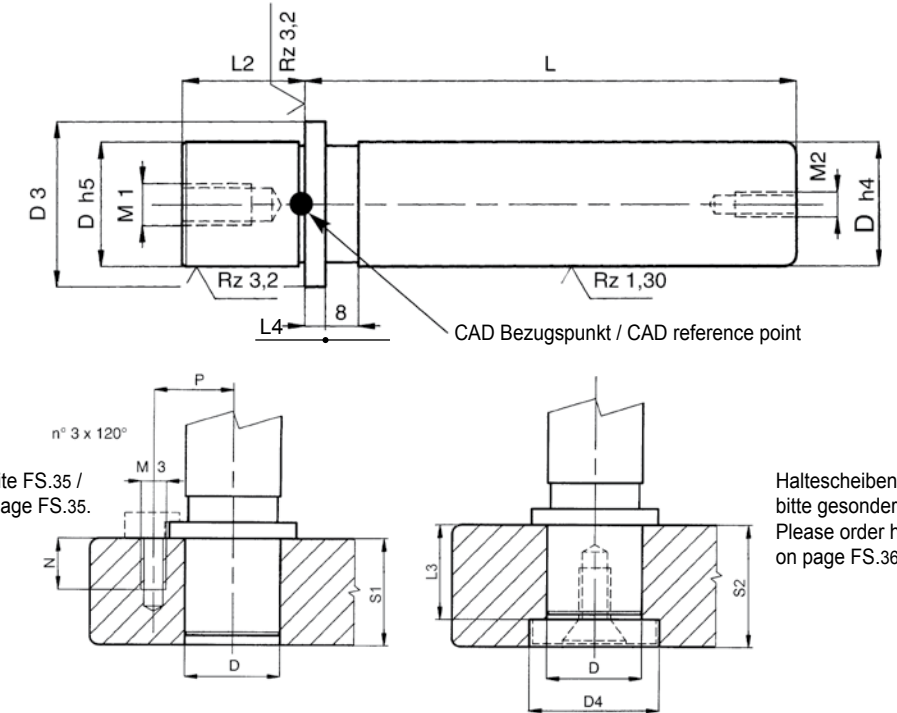

Haltestücke **FS 955** siehe Seite FS.35 /
Holding clamps **FS 955** see page FS.35.

Haltescheiben **FS 958** auf Seite FS.36
bitte gesondert bestellen. /
Please order holding discs **FS 958**
on page FS.36 separately.



D	D3	D4	L2	L3	L4	M1	M2	M3	N	P	S1min	S2min
18	25	27	20	21	5	M8	M6	M6	12	16	23	28
19	25	27	20	21	5	M8	M6	M6	12	16	23	28
24	32	34	25	26	5	M10	M6	M6	12	19,5	28	33
25	32	34	25	26	5	M10	M6	M6	12	19,5	28	33
30	40	41	30	31	5	M10	M6	M8	16	25	33	38
32	40	41	30	31	5	M10	M6	M8	16	25	33	38
40	50	52	35	36	5	M12	M8	M8	16	30	38	48
42	50	52	35	36	5	M12	M8	M8	16	30	38	48
50	62	64	45	46	5	M12	M8	M8	16	36	48	58
52	62	64	45	46	5	M12	M8	M8	16	36	48	58
63	73	75	49	50	5	M12	M10	M8	16	41,5	53	63
80	93	95	59	60	5	M12	M10	M8	16	51,5	63	73
100	120	122	80	81	8	M16	M16	-	-	-	-	104

D	L																Aufnahmebohrung Mounting hole JS6							
	100	110	120	130	140	150	160	170	180	200	220	240	260	280	300	320		360	400					
18-19	•	•	•	•	•	•	•	•	•														±0,006	
24-25	•	•	•	•	•	•	•	•	•															±0,006
30-32			•	•	•	•	•	•	•	•														±0,006
40-42				•	•	•	•	•	•	•	•	•	•	•	•	•	•	•	•	•				±0,006
50-52						•	•	•	•	•	•	•	•	•	•	•	•	•	•	•	•			±0,006
63							•	•	•	•	•	•	•	•	•	•	•	•	•	•	•			±0,010
80										•	•	•	•	•	•	•	•	•	•	•	•	•		±0,010
100														•	•	•	•	•	•	•	•	•		±0,010

FS 410

Mat.: Stahl
Oberflächenhärte: 60 - 64 HRC
Einhärtungstiefe: 1,5 + 1 mm

Mat.: steel
Surface hardness: 60 - 64 HRC
Hardening depth: 1,5 + 1 mm

FS 410 / 50 x 200

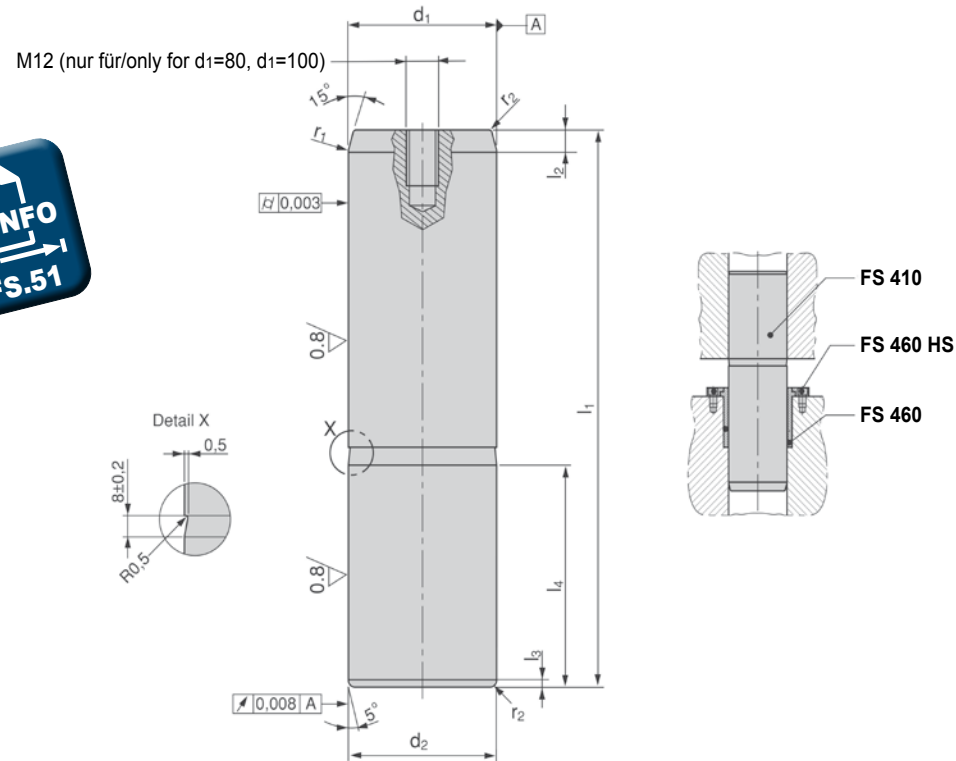

d1 f6	l1 -1												l2 +0,8	l3 +0,8	l4 +0,8	d2 r6	r1	r2
	125	140	160	180	200	224	250	280	315	355	400	450						
25	•	•	•	•	•	•							8	4	40	25	3	2
32		•	•	•	•	•	•						8	4	45	32	3	2
40		•	•	•	•	•	•	•					8	4	56	40	3	2
50			•	•	•	•	•	•	•				10	4	70	50	5	2,5
63				•	•	•	•	•	•	•			10	4	80	63	6	2,5
80					•	•	•	•	•	•	•		10	4	100	80	8	3
100						•	•	•	•	•	•	•	10	4	125	100	10	3



FS 412

Mat.: Stahl
Oberflächenhärte: 60 - 64 HRC
Einhärtungstiefe: 1,5 + 1 mm

Mat.: steel
Surface hardness: 60 - 64 HRC
Hardening depth: 1,5 + 1 mm

FS 412 / 50 x 200

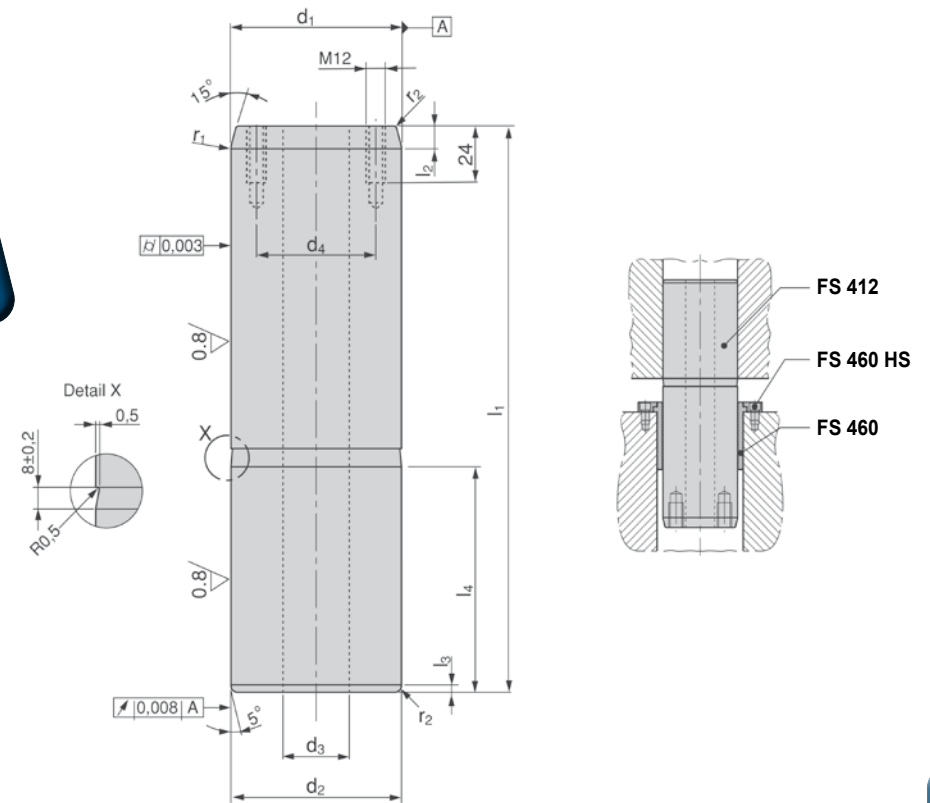

d1 f6	l1										l2 +0,8	l3 +0,8	l4 +0,8	d2 r6	d3 ±2	d4 +0,8	r1	r2
	200	224	250	280	315	355	400	450	500	560								
80	•	•	•	•	•	•	•	•			10	4	100	80	40	58	8	3
100		•	•	•	•	•	•	•			10	4	125	100	50	72	10	3
125					•	•	•	•	•		12	4	140	125	65	90	12	4
160								•	•	•	12	5	180	160	95	132	18	4



mit langem Bund/long-headed style

FS 440 ... RM
FS 450 ... RM

Mat.: 1.6757 / 61 - 63 HRC
RM-beschichtet (selbstschmierend)

Mat.: 1.6757 / 61 - 63 HRC
RM-coated (self lubricating)

FS 450 / 40 x 90 / RM

Lieferumfang:
• 3 Halteklammern mit Schrauben

Included:
• 3 holding clamps with screws

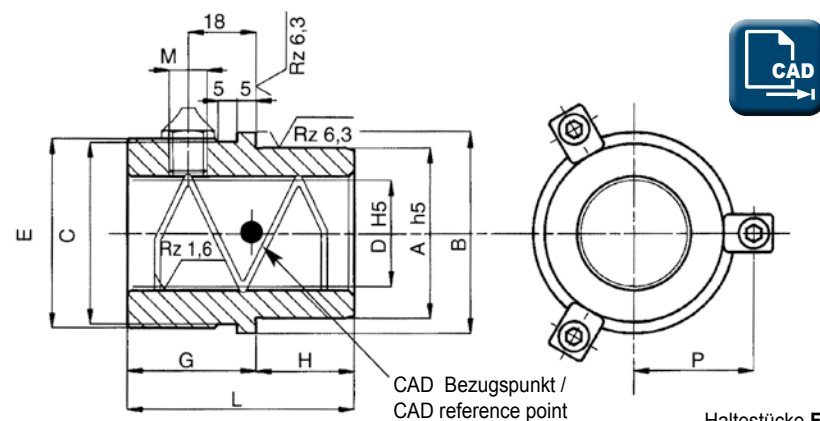

Haltestücke **FS 955** siehe Seite FS.35 /
Holding clamps **FS 955** see page FS.35.

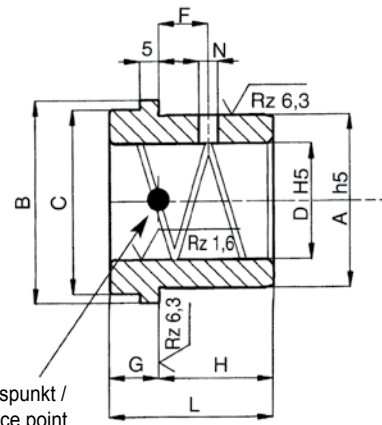

mit kurzem Bund/short-headed style

FS 430 ... RM
FS 439 ... RM

CAD Bezugspunkt /
CAD reference point



D	A	B	C	Artikelnummer Article number	E	F	G	H	L	M	N	P	Aufnahmebohrung Mounting hole H6
18-19	28	34	29	FS 430 ... RM	-	8	13	18	31	-	5	20,5	28 ^{+0,013}
18-19	28	34	29	FS 439 ... RM	-	8	13	37	50	-	5	20,5	28 ^{+0,013}
18-19	28	34	29	FS 440 ... RM	31	-	32	18	50	M6	-	20,5	28 ^{+0,013}
18-19	28	34	29	FS 450 ... RM	31	-	33	27	60	M6	-	20,5	28 ^{+0,013}
24-25	38	44	39	FS 430 ... RM	-	9	13	23	36	-	5	25,5	38 ^{+0,016}
24-25	38	44	39	FS 439 ... RM	-	12	13	42	55	-	5	25,5	38 ^{+0,016}
24-25	38	44	39	FS 440 ... RM	41	-	32	23	55	M10 x 1	-	25,5	38 ^{+0,016}
24-25	38	44	39	FS 450 ... RM	41	-	38	32	70	M10 x 1	-	25,5	38 ^{+0,016}
30-32	45	53	48	FS 430 ... RM	-	11	13	30	43	-	5	31,5	45 ^{+0,016}
30-32	45	53	48	FS 439 ... RM	-	19	13	47	60	-	5	31,5	45 ^{+0,016}
30-32	45	53	48	FS 440 ... RM	50	-	34	26	60	M10 x 1	-	31,5	45 ^{+0,016}
30-32	45	53	48	FS 450 ... RM	50	-	43	37	80	M10 x 1	-	31,5	45 ^{+0,016}
40-42	54	63	58	FS 430 ... RM	-	11	13	38	51	-	8	36,5	54 ^{+0,019}
40-42	54	63	58	FS 439 ... RM	-	19	13	54	67	-	8	36,5	54 ^{+0,019}
40-42	54	63	58	FS 440 ... RM	60	-	37	30	67	M10 x 1	-	36,5	54 ^{+0,019}
40-42	54	63	58	FS 450 ... RM	60	-	43	47	90	M10 x 1	-	36,5	54 ^{+0,019}
50-52	65	79	74	FS 430 ... RM	-	14	13	48	61	-	8	44,5	65 ^{+0,019}
50-52	65	79	74	FS 439 ... RM	-	19	13	62	75	-	8	44,5	65 ^{+0,019}
50-52	65	79	74	FS 440 ... RM	76	-	40	35	75	M10 x 1	-	44,5	65 ^{+0,019}
50-52	65	79	74	FS 450 ... RM	76	-	43	57	100	M10 x 1	-	44,5	65 ^{+0,019}

mit langem Bund/long-headed style

FS 741
FS 751
FS 755

Mat.: Stahl 61 - 63 HRC
Sinter: 40 - 50 HRC

Mat.: Steel 61 - 63 HRC
Sinter: 40 - 50 HRC

FS 751 / 30 x 90

Lieferumfang:
• 3 Halteklammern mit Schrauben

Included:
• 3 holding clamps with screws

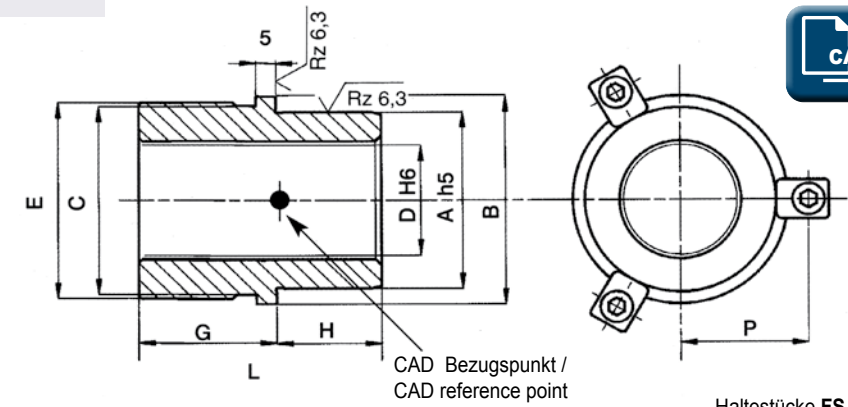
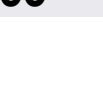

Haltestücke **FS 955** siehe Seite FS.35 /
Holding clamps **FS 955** see page FS.35.

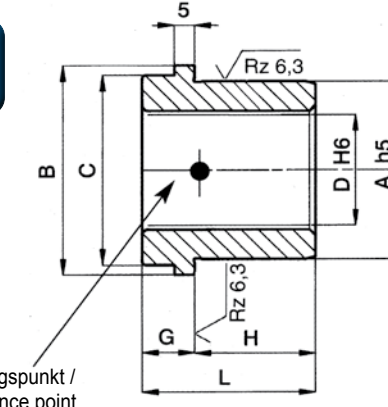

mit kurzem Bund/short-headed style

FS 731
FS 732

CAD Bezugspunkt /
CAD reference point



D	A	B	C	Artikelnummer Article number	E	G	H	L	P	Aufnahmebohrung Mounting hole H6
18-19	28	34	29	FS 731	-	13	18	31	20,5	28 ^{+0,013}
18-19	28	34	29	FS 732	-	13	37	50	20,5	28 ^{+0,013}
18-19	28	34	29	FS 741	31	32	18	50	20,5	28 ^{+0,013}
18-19	28	34	29	FS 751	31	43	27	70	20,5	28 ^{+0,013}
18-19	28	34	29	FS 755	31	52	18	70	20,5	28 ^{+0,013}
24-25	38	44	39	FS 731	-	13	23	36	25,5	38 ^{+0,016}
24-25	38	44	39	FS 732	-	13	42	55	25,5	38 ^{+0,016}
24-25	38	44	39	FS 741	41	32	23	55	25,5	38 ^{+0,016}
24-25	38	44	39	FS 751	41	48	32	80	25,5	38 ^{+0,016}
24-25	38	44	39	FS 755	41	57	23	80	25,5	38 ^{+0,016}
30-32	45	53	48	FS 731	-	13	30	43	31,5	45 ^{+0,016}
30-32	45	53	48	FS 732	-	13	47	60	31,5	45 ^{+0,016}
30-32	45	53	48	FS 741	50	34	26	60	31,5	45 ^{+0,016}
30-32	45	53	48	FS 751	50	53	37	90	31,5	45 ^{+0,016}
30-32	45	53	48	FS 755	50	64	26	90	31,5	45 ^{+0,016}
40-42	54	63	58	FS 731	-	13	38	51	36,5	54 ^{+0,019}
40-42	54	63	58	FS 732	-	13	54	67	36,5	54 ^{+0,019}
40-42	54	63	58	FS 741	60	37	30	67	36,5	54 ^{+0,019}
40-42	54	63	58	FS 751	60	53	47	100	36,5	54 ^{+0,019}
40-42	54	63	58	FS 755	60	70	30	100	36,5	54 ^{+0,019}
50-52	65	79	74	FS 731	-	13	48	61	44,5	65 ^{+0,019}
50-52	65	79	74	FS 732	-	13	62	75	44,5	65 ^{+0,019}
50-52	65	79	74	FS 741	76	40	35	75	44,5	65 ^{+0,019}
50-52	65	79	74	FS 751	76	53	57	110	44,5	65 ^{+0,019}
50-52	65	79	74	FS 755	76	75	35	110	44,5	65 ^{+0,019}

Führungsbuchsen mit Bund, Stahlführung

Leader pin bushings with collar, steel

FÜHRUNGSSYSTEME / GUIDINGSYSTEMS



mit langem Bund/long-headed style

FS 741

FS 751

FS 755

Mat.: Stahl 61 - 63 HRC
Sinter: 40 - 50 HRC

Mat.: Steel 61 - 63 HRC
Sinter: 40 - 50 HRC

FS 751 / 63 x 130

Lieferumfang:

- 3 Halteklammern mit Schrauben

Included:

- 3 holding clamps with screws

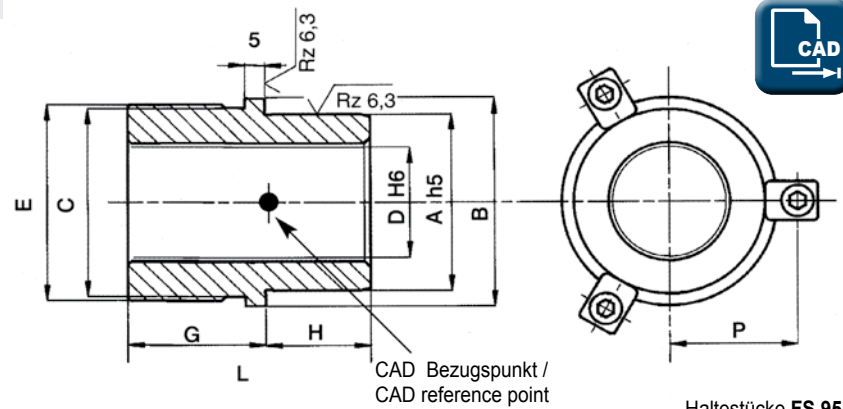

CAD Bezugspunkt /
CAD reference point

Haltestücke **FS 955** siehe Seite FS.35 /
Holding clamps **FS 955** see page FS.35.

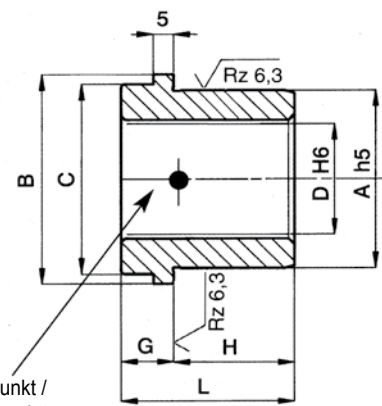

mit kurzem Bund/short-headed style

FS 731

FS 732

CAD Bezugspunkt /
CAD reference point



D	A	B	C	Artikelnummer Article number	E	G	H	L	P	Aufnahmebohrung Mounting hole H6
63	81	92	87	FS 731	-	13	61	74	51	81 ^{+0,022}
63	81	92	87	FS 732	-	13	77	90	51	81 ^{+0,022}
63	81	92	87	FS 741	89	42	48	90	51	81 ^{+0,022}
63	81	92	87	FS 751	89	63	67	130	51	81 ^{+0,022}
63	81	92	87	FS 755	89	82	48	130	51	81 ^{+0,022}
80	100	111	106	FS 731	-	13	78	91	60,5	100 ^{+0,022}
80	100	111	106	FS 741	108	52	48	100	60,5	100 ^{+0,022}
80	100	111	106	FS 751	108	73	77	150	60,5	100 ^{+0,022}
80	100	111	106	FS 755	108	102	48	150	60,5	100 ^{+0,022}

Führungsbuchsen mit Bund, Bronze beschichtet

Leader pin bushings with collar, bronze plated

FÜHRUNGSSYSTEME / GUIDINGSYSTEMS



mit langem Bund/long-headed style

FS 641

FS 651

FS 655

Mat.: 1.6757 / 61 - 63 HRC
Bronze: 40 - 45 HRC

Mat.: 1.6757 / 61 - 63 HRC
Bronze: 40 - 45 HRC

FS 651 / 30 x 90

Lieferumfang:

- 3 Halteklammern mit Schrauben

Included:

- 3 holding clamps with screws

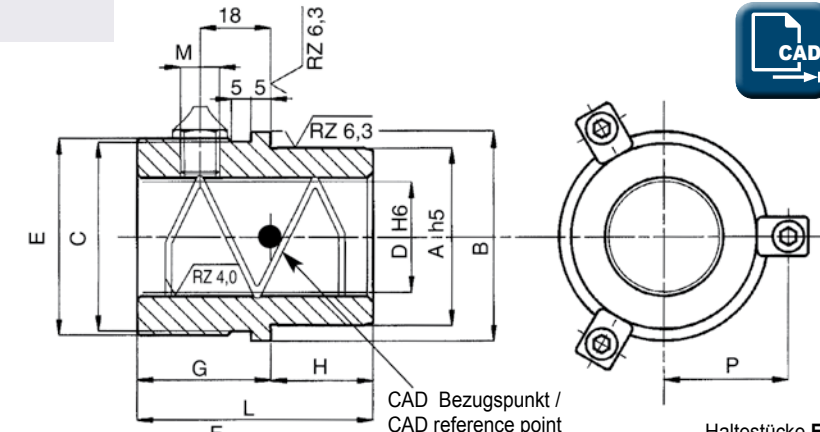

CAD Bezugspunkt /
CAD reference point

Haltestücke **FS 955** siehe Seite FS.35 /
Holding clamps **FS 955** see page FS.35.

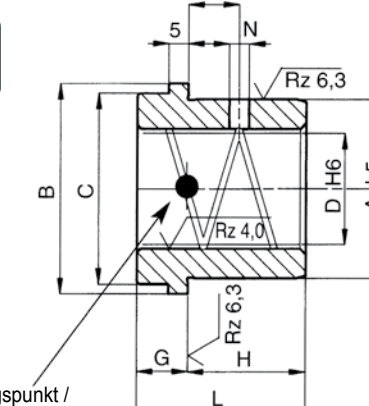

mit kurzem Bund/short-headed style

FS 631

FS 632

CAD Bezugspunkt /
CAD reference point



D	A	B	C	Artikelnummer Article number	E	F	G	H	L	M	N	P	Aufnahmebohrung Mounting hole H6
18-19	28	34	29	FS 631	-	8	13	18	31	-	5	20,5	28 ^{+0,013}
18-19	28	34	29	FS 632	-	8	13	37	50	-	5	20,5	28 ^{+0,013}
18-19	28	34	29	FS 641	31	-	32	18	50	M6	-	20,5	28 ^{+0,013}
18-19	28	34	29	FS 651	31	-	43	27	70	M6	-	20,5	28 ^{+0,013}
18-19	28	34	29	FS 655	31	-	52	18	70	M6	-	20,5	28 ^{+0,013}
24-25	38	44	39	FS 631	-	12	13	23	36	-	5	25,5	38 ^{+0,016}
24-25	38	44	39	FS 632	-	12	13	42	55	-	5	25,5	38 ^{+0,016}
24-25	38	44	39	FS 641	41	-	32	23	55	M10 x 1	-	25,5	38 ^{+0,016}
24-25	38	44	39	FS 651	41	-	48	32	80	M10 x 1	-	25,5	38 ^{+0,016}
24-25	38	44	39	FS 655	41	-	57	23	80	M10 x 1	-	25,5	38 ^{+0,016}
30-32	45	53	48	FS 631	-	16	13	30	43	-	5	31,5	45 ^{+0,016}
30-32	45	53	48	FS 632	-	16	13	47	60	-	5	31,5	45 ^{+0,016}
30-32	45	53	48	FS 641	50	-	34	26	60	M10 x 1	-	31,5	45 ^{+0,016}
30-32	45	53	48	FS 651	50	-	53	37	90	M10 x 1	-	31,5	45 ^{+0,016}
30-32	45	53	48	FS 655	50	-	64	26	90	M10 x 1	-	31,5	45 ^{+0,016}
40-42	54	63	58	FS 631	-	19	13	38	51	-	8	36,5	54 ^{+0,019}
40-42	54	63	58	FS 632	-	19	13	54	67	-	8	36,5	54 ^{+0,019}
40-42	54	63	58	FS 641	60	-	37	30	67	M10 x 1	-	36,5	54 ^{+0,019}
40-42	54	63	58	FS 651	60	-	53	47	100	M10 x 1	-	36,5	54 ^{+0,019}
40-42	54	63	58	FS 655	60	-	70	30	100	M10 x 1	-	36,5	54 ^{+0,019}
50-52	65	79	74	FS 631	-	19	13	48	61	-	8	44,5	65 ^{+0,019}
50-52	65	79	74	FS 632	-	19	13	62	75	-	8	44,5	65 ^{+0,019}
50-52	65	79	74	FS 641	76	-	40	35	75	M10 x 1	-	44,5	65 ^{+0,019}
50-52	65	79	74	FS 651	76	-	53	57	110	M10 x 1	-	44,5	65 ^{+0,019}
50-52	65	79	74	FS 655	76	-	75	35	110	M10 x 1	-	44,5	65 ^{+0,019}

Führungsbuchsen mit Bund, Bronze beschichtet

Leader pin bushings with collar, bronze plated



FÜHRUNGSSYSTEME / GUIDINGSYSTEMS

mit langem Bund/long-headed style

FS 641

FS 651

FS 655

Mat.: 1.6757 / 61 - 63 HRC
Bronze: 40 - 45 HRC

Lieferumfang:
• 3 Halteklammern mit Schrauben

Mat.: 1.6757 / 61 - 63 HRC
Bronze: 40 - 45 HRC

Included:
• 3 holding clamps with screws

FS 651 / 63 x 130

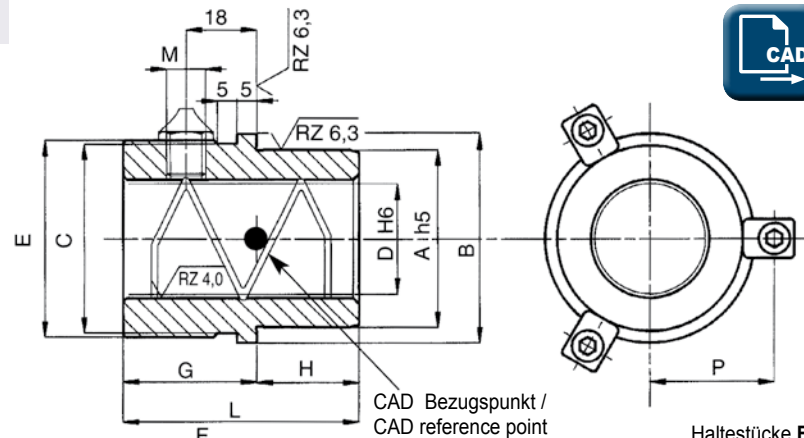

CAD Bezugspunkt /
CAD reference point

Haltestücke **FS 955** siehe Seite FS.35 /
Holding clamps **FS 955** see page FS.35.

mit kurzem Bund/short-headed style

FS 631

FS 632

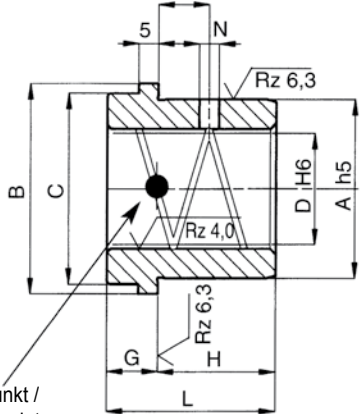

CAD Bezugspunkt /
CAD reference point

D	A	B	C	Artikelnummer Article number	E	F	G	H	L	M	N	P	Aufnahmebohrung Mounting hole H6
63	81	92	87	FS 631	-	19	13	61	74	-	8	51	81 ^{+0,022}
63	81	92	87	FS 632	-	19	13	77	90	-	8	51	81 ^{+0,022}
63	81	92	87	FS 641	89	-	42	48	90	M10 x 1	-	51	81 ^{+0,022}
63	81	92	87	FS 651	89	-	63	67	130	M10 x 1	-	51	81 ^{+0,022}
63	81	92	87	FS 655	89	-	82	48	130	M10 x 1	-	51	81 ^{+0,022}
80	100	111	106	FS 631	-	19	13	78	91	-	8	60,5	100 ^{+0,022}
80	100	111	106	FS 641	108	-	52	48	100	-	8	60,5	100 ^{+0,022}
80	100	111	106	FS 651	108	-	73	77	150	M10 x 1	-	60,5	100 ^{+0,022}
80	100	111	106	FS 655	108	-	102	48	150	M10 x 1	-	60,5	100 ^{+0,022}

Führungsbuchsen mit Bund, Kugelführung

Leader pin bushings with collar, ball bearing



FÜHRUNGSSYSTEME / GUIDINGSYSTEMS

FS 457

FS 458

FS 453

Mat.: 1.6757 / 61 - 63 HRC

Lieferumfang:
• 3 Halteklammern mit Schrauben

Mat.: 1.6757 / 61 - 63 HRC

Included:
• 3 holding clamps with screws

FS 453 / 30 x 90

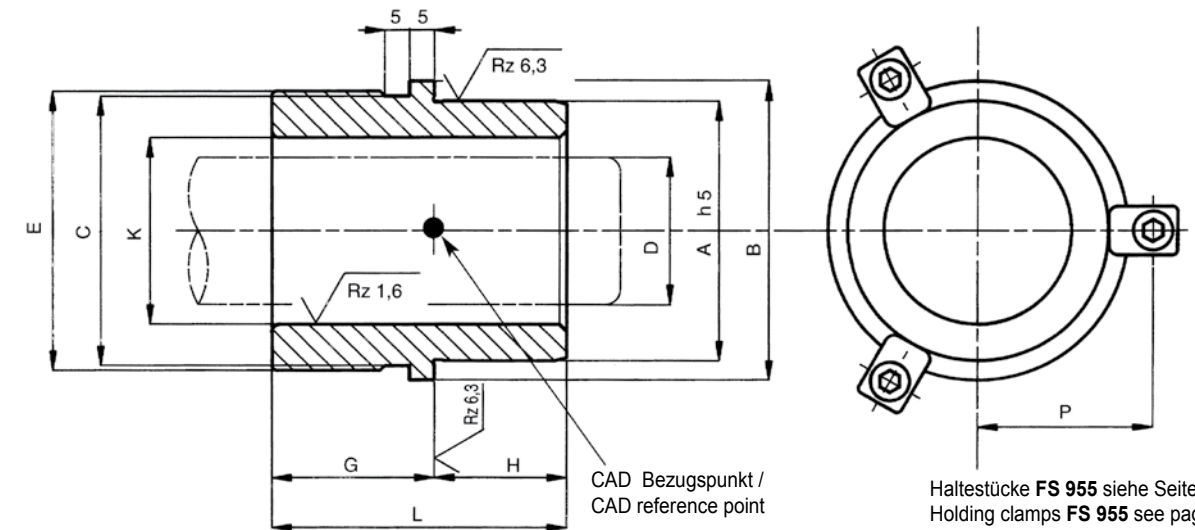

CAD Bezugspunkt /
CAD reference point

Haltestücke **FS 955** siehe Seite FS.35 /
Holding clamps **FS 955** see page FS.35.

D	K	A	B	C	Artikelnummer Article number	E	G	H	L	P	Aufnahmebohrung Mounting hole H6
18-19	24-25	34	40	34	FS 457	-	13	18	31	23,5	34 ^{+0,013}
18-19	24-25	34	40	34	FS 458	36	32	18	50	23,5	34 ^{+0,013}
18-19	24-25	34	40	34	FS 453	36	43	27	70	23,5	34 ^{+0,013}
24-25	30-31	44	50	44	FS 457	-	13	22	35	28,5	44 ^{+0,016}
24-25	30-31	44	50	44	FS 458	46	33	22	55	28,5	44 ^{+0,016}
24-25	30-31	44	50	44	FS 453	46	48	32	80	28,5	44 ^{+0,016}
30-32	38-40	53	61	55	FS 457	-	13	27	40	35,5	53 ^{+0,016}
30-32	38-40	53	61	55	FS 458	57	33	27	60	35,5	53 ^{+0,016}
30-32	38-40	53	61	55	FS 453	57	53	37	90	35,5	53 ^{+0,016}
40-42	48-50	62	71	65	FS 457	-	13	32	45	40,5	62 ^{+0,019}
40-42	48-50	62	71	65	FS 458	67	40	27	67	40,5	62 ^{+0,019}
40-42	48-50	62	71	65	FS 453	67	53	47	100	40,5	62 ^{+0,019}
50-52	58-60	73	87	81	FS 457	-	13	37	50	48,5	73 ^{+0,019}
50-52	58-60	73	87	81	FS 458	83	43	32	75	48,5	73 ^{+0,019}
50-52	58-60	73	87	81	FS 453	83	53	57	110	48,5	73 ^{+0,019}

ØD = 63 und 80 auf Anfrage / ØD = 63 and 80 on request

Kugelkäfige aus Messing

Ball cages, brass

FÜHRUNGSSYSTEME / GUIDINGSYSTEMS



FS 425

Mat.: Messing
Stahlkugeln: Güteklasse AAA

Mat.: Brass
Steel balls, grade AAA

FS 425 / 25 x 90

Sicherungsring im Lieferumfang enthalten.

Safety ring included

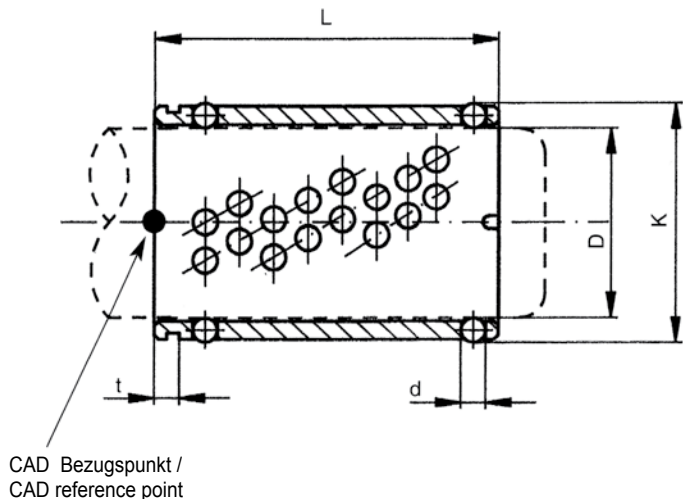

CAD Bezugspunkt / CAD reference point



D	K	d	t	L	Anzahl Kugeln Number of balls
18	24	3	2,9	45	144
				56	176
				71	224
19	25	3	3,6	80	272
				45	171
24	30	3	4,8	71	285
				90	361
30	38	4	4,8	56	160
				75	228
32	40	4	5,5	95	300
				105	340
40	48	4	5,5	63	230
				80	299
42	50	4	5,5	120	460
				80	336
50	58	4	5,5	95	405
				140	616
52	60	4	5,5	140	616

ØD = 63 und 80 auf Anfrage / ØD = 63 and 80 on request

Abgehängte Kugelkäfige mit Befestigungselementen

Ball cages with circlip incl. mounting elements

FÜHRUNGSSYSTEME / GUIDINGSYSTEMS



FS 424

Mat.: Aluminium
Stahlkugeln: Güteklasse AAA

Mat.: Aluminium
Steel balls, grade AAA

FS 424 / 32 x 105

Jeder Kugelkäfig wird mit Befestigungselementen (siehe Seite FS.29/30) geliefert.

Each ball cage supplied with mounting elements (please see page FS.29/30).

Kugelkäfige vorzugsweise für den Einbau im Unterteil.

Ball cages, preferably for mounting in the lower half of the die.

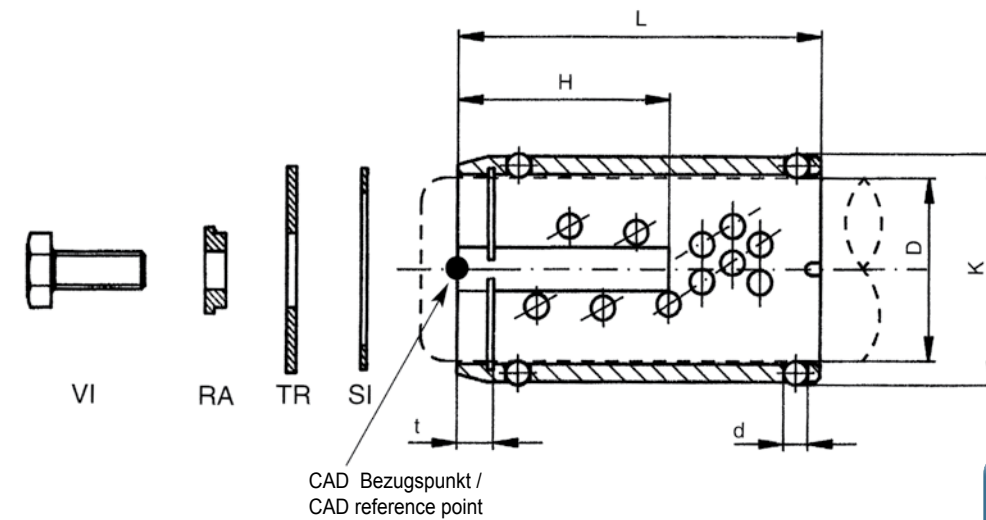

CAD Bezugspunkt / CAD reference point



D	K	d	t	H	L	Anzahl Kugeln Number of balls
18	24	3	4	24	44	66
18	24	3	4	36	60	93
18	24	3	4	44	80	141
19	25	3	4	24	44	66
19	25	3	4	36	60	93
19	25	3	4	44	80	141
24	30	3	4	32	52	100
24	30	3	4	40	72	149
24	30	3	4	48	92	198
25	31	3	4	32	52	100
25	31	3	4	40	72	149
25	31	3	4	48	92	198
30	38	4	5	35	60	112
30	38	4	5	45	75	145
30	38	4	5	55	105	204
32	40	4	5	35	60	112
32	40	4	5	45	75	145
32	40	4	5	55	105	204

FS 424

Mat.: Aluminium
Stahlkugeln: Güteklasse AAA

Mat.: Aluminium
Steel balls, grade AAA

FS 424 / 52 x 105

Jeder Kugelkäfig wird mit Befestigungselementen (siehe Seite FS.29/30) geliefert.

Each ball cage supplied with mounting elements (please see page FS.29/30).

Kugelkäfige vorzugsweise für den Einbau im Unterteil.

Ball cages, preferably for mounting in the lower half of the die.

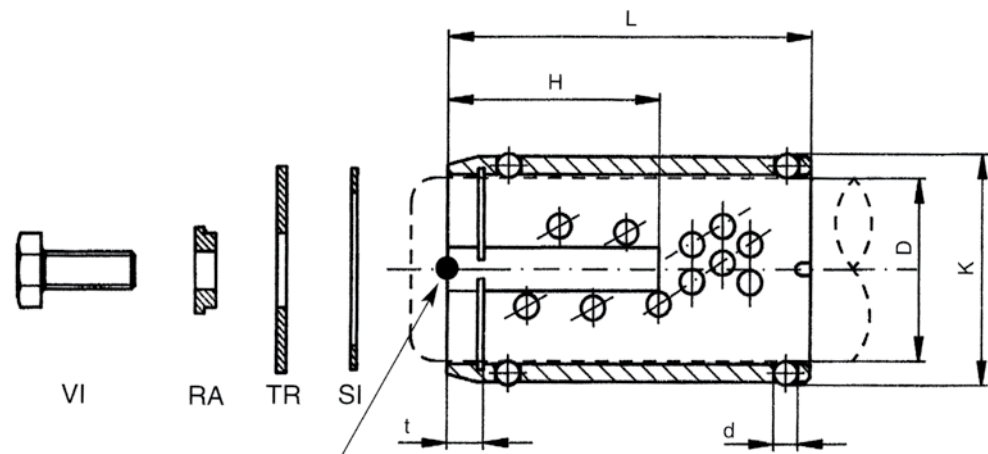

CAD Bezugspunkt / CAD reference point



D	K	d	t	H	L	Anzahl Kugeln Number of balls
40	48	4	5	40	70	159
40	48	4	5	50	85	198
40	48	4	5	75	120	288
42	50	4	5	40	70	159
42	50	4	5	50	85	198
42	50	4	5	75	120	288
50	58	4	5	45	90	245
50	58	4	5	55	105	293
50	58	4	5	80	130	363
52	60	4	5	45	90	245
52	60	4	5	55	105	293
52	60	4	5	80	130	363

FS 424 / SI

FS 424 / SI 1

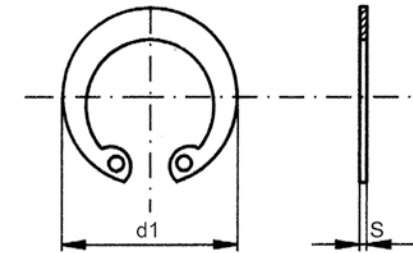

Größe Size	D FS 424	d1	S
SI 1	18	19	1
SI 2	19	20	1
SI 3	24	25	1,2
SI 4	25	26	1,2
SI 5	30	31	1,2
SI 6	32	33	1,2
SI 7	40	41	1,75
SI 8	42	43	1,75
SI 9	50	51	2
SI 10	52	53	2

FS 424 / TR

FS 424 / TR 1

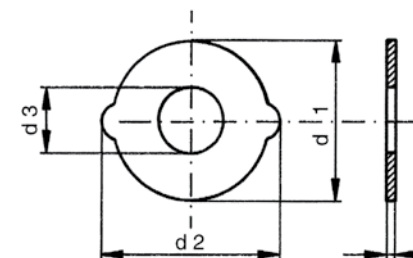

Größe Size	D FS 424	d1	d2	d3	S
TR 1	18	17,5	20,8	12	1,5
TR 2	19	18,5	21,8	12	1,5
TR 3	24	23,5	26,8	12	1,5
TR 4	25	24,5	27,8	12	1,5
TR 5	30	29,5	34,2	12	1,5
TR 6	32	31,5	36,2	12	1,5
TR 7	40	39,5	44,2	15	2
TR 8	42	41,5	46,2	15	2
TR 9	50	49,5	54,2	15	2
TR 10	52	51,5	56,5	15	2

FS 424 / RA

FS 424 / RA 1

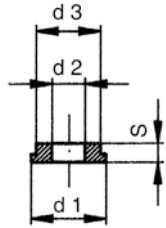

Größe Size	D FS 424	d1	d2	d3	S
RA 1	18	14	6,3	11,8	3,5
RA 1	19	14	6,3	11,8	3,5
RA 1	24	14	6,3	11,8	3,5
RA 1	25	14	6,3	11,8	3,5
RA 1	30	14	6,3	11,8	3,5
RA 1	32	14	6,3	11,8	3,5
RA 2	40	18	8,3	14,7	4,5
RA 2	42	18	8,3	14,7	4,5
RA 2	50	18	8,3	14,7	4,5
RA 2	52	18	8,3	14,7	4,5

FS 424 / VI

FS 424 / VI 1

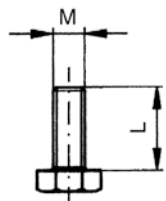

Größe Size	D FS 424	M	L
VI 1	18	M6	15
VI 1	19	M6	15
VI 1	24	M6	15
VI 1	25	M6	15
VI 1	30	M6	15
VI 1	32	M6	15
VI 2	40	M8	18
VI 2	42	M8	18
VI 2	50	M8	18
VI 2	52	M8	18

FS 460

mit Bund
Mat.: Bronze-Graphit

with collar
Mat.: Bronze-graphite

FS 460 / 40

Haltestücke bitte gesondert bestellen!

Holding clamps need to be ordered separately!

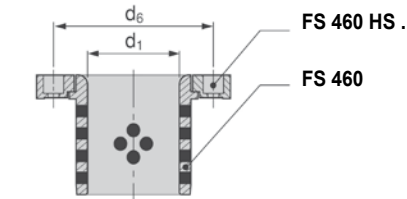
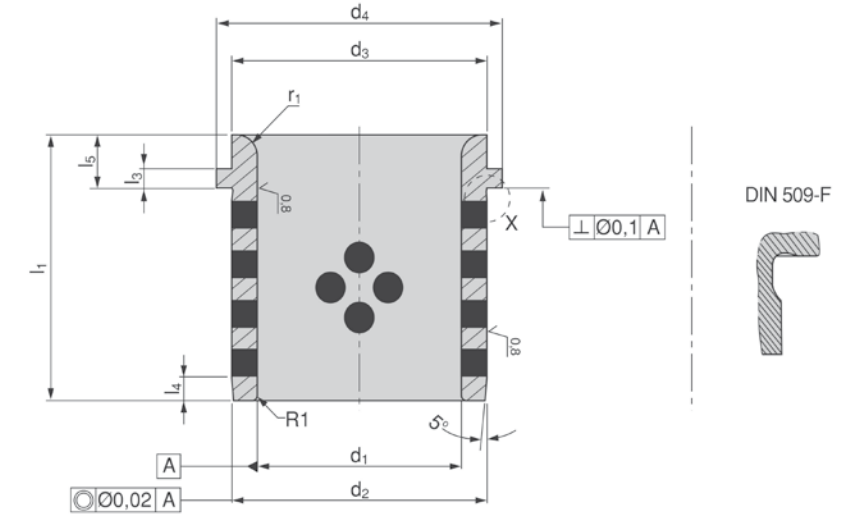

d1 H7	d2 h6	d3 -0,25	d4 -0,8	d6 ±0,3	l1 -0,5/-1	l3 ±0,1	l4 ±1	l5 -0,5	r1	Haltestücke Typ Holding clamps type
25	32	32	40	58	40	6,3	3	10	3	FS 460 HS 1
32	40	40	50	66	50	6,3	4	12	3	FS 460 HS 1
40	50	50	63	79	63	6,3	5	15	3	FS 460 HS 1
50	63	63	71	89	71	6,3	6,3	17	5	FS 460 HS 1
63	80	80	90	123	80	10	8	19	6	FS 460 HS 2
80	100	100	112	143	100	10	10	22	8	FS 460 HS 2
100	125	125	140	168	125	10	12,5	21	10	FS 460 HS 2
125	160	160	180	203	160	10	16	30	12	FS 460 HS 2
160	200	200	220	243	200	10	16	32	18	FS 460 HS 2

FS 460 HS .

für Führungsbuchse FS 460 nach DIN 9834 / ISO 9448

for leader pin bushings FS 460 DIN 9834 / ISO 9448

FS 460 HS 1

Mat.: CK45

Mat.: CK45

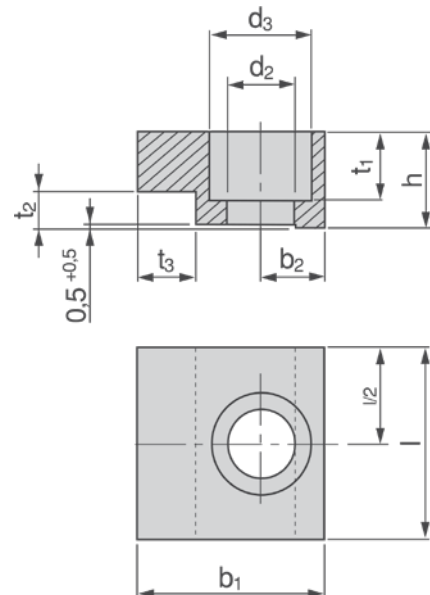

Typ Type	b1	b2	d2 +0,2	d3 +0,2	h	l -0,3	t1	t2	t3	Ø Buchse Ø Bushing	Schraube Screw
HS 1	20	7,5	7	11	10	20	7	6,3	5	25-50	M6x16
HS 2	32	11,0	11,5	17,5	16	32	11,5	10	10	63-160	M10x20

FS 460 HS 3

Mat.: CK45

Mat.: CK45

FS 460 HS 3

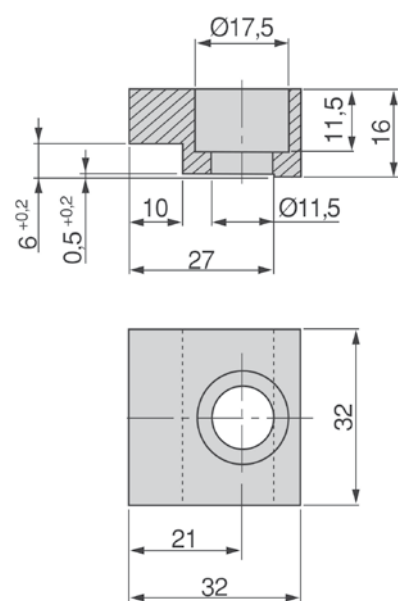

FS 461

mit Bund
Mat.: Bronze-Graphit

with collar
Mat.: Bronze-graphite

FS 461 / 40

Haltestücke bitte gesondert bestellen!

Holding clamps need to be ordered separately!

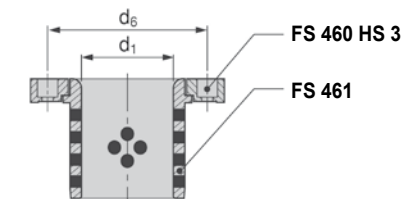
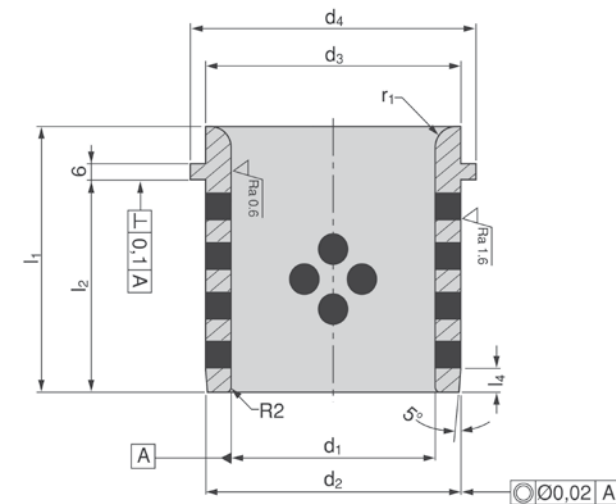

d1 H7	d2 g6	d3 -0,25	d4 -0,8	d6 ±0,3	l1 -0,5	l2	l4	r1	Haltestücke Typ Holding clamps type
25	32	32	40	75	40	30	4	3	FS 460 HS 3
32	40	40	50	83	50	40	4	3	FS 460 HS 3
40	50	50	63	93	63	50	5	3	FS 460 HS 3
50	63	63	71	106	71	56	6	5	FS 460 HS 3
63	80	80	90	123	80	63	8	6	FS 460 HS 3
80	100	100	112	143	100	80	10	8	FS 460 HS 3
100	125	125	140	168	125	106	12	10	FS 460 HS 3
125	160	160	180	203	160	132	12	12	FS 460 HS 3

FS 462

ohne Bund
Mat.: Bronze-Graphit

without collar
Mat.: Bronze-graphite

FS 462 / 20 x 28 x 30

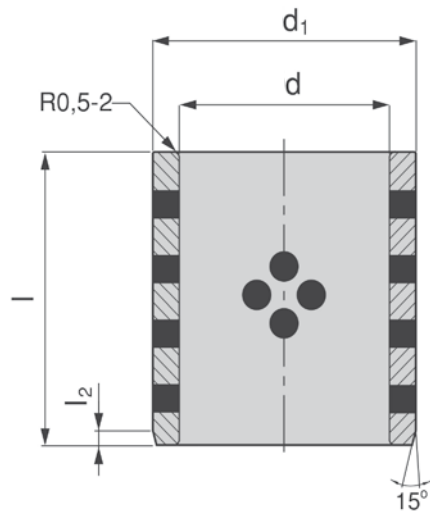

d	d1	l																l2	
		-0,1/-0,3																	
F7	m6	8	10	12	15	16	20	25	30	35	40	50	60	70	80	100	120		
8	12	•	•	•	•														2
10	14		•	•	•		•												2
12	18		•	•		•	•	•	•										2
16	22			•		•	•	•	•	•	•								2
18	24						•	•	•	•	•	•							2
20	28						•	•	•	•	•	•	•						2
20	30					•	•	•	•	•	•	•	•						2
25	33						•	•	•	•	•	•	•	•					2
25	35						•	•	•	•	•	•	•	•	•				2
30	38							•	•	•	•	•	•	•	•				2
30	40						•		•	•	•	•	•	•	•				2
35	44									•	•	•	•	•	•				2
35	45								•	•	•	•	•	•	•				2
40	50							•	•	•	•	•	•	•	•				2
40	55									•	•	•	•	•	•				2
50	60											•	•	•	•				2
50	62												•	•	•				2
50	65												•	•	•				2
60	75													•	•	•			2
70	85														•	•	•		2
80	96															•	•		2
80	100															•	•		2
100	120																•	•	2
110	130																	•	2
130	150																		4

FS 955

Haltestücke werden mit Schrauben
geliefert

Holding clamps come with correspond-
ing screws

FS 955 / A

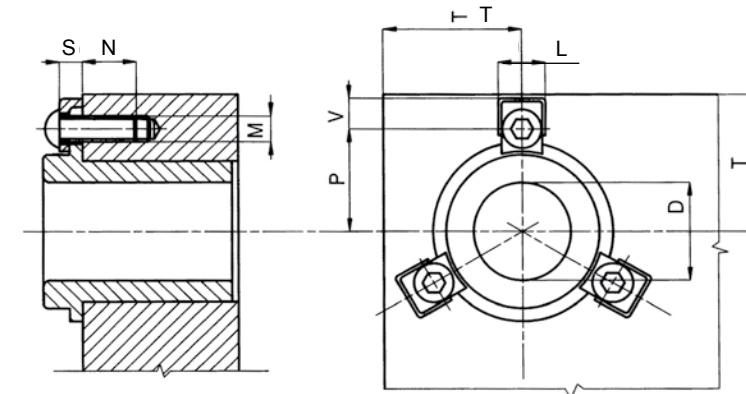

Ausführung Style	D	L	M	N	S	V
A	18-19	12	M6	12	6,7	6,0
A	24-25	12	M6	12	6,7	6,0
B	30-32	14,5	M8	16	7	7,2
B	40-42	14,5	M8	16	7	7,2
B	50-52	14,5	M8	16	7	7,2
B	63-80	14,5	M8	16	7	7,2

für Bundbuchsen mit Stahl- oder Bronzebeschichtung for leader pin bushings with collar steel or bronze-plated			für Bundbuchsen mit Kugelführung for leader pin bushings with collar ball cage		
D	P	T	D	P	T
18-19	20,5	32	18-19	23,5	35
24-25	25,5	37	24-25	28,5	40
30-32	31,5	44	30-32	35,5	48
40-42	36,5	49	40-42	40,5	53
50-52	44,5	57	50-52	48,5	61
63	51	64			
80	60,5	73			

Anordnung der Haltestücke bei Stahlgestellen / Location of holding clamps in die sets

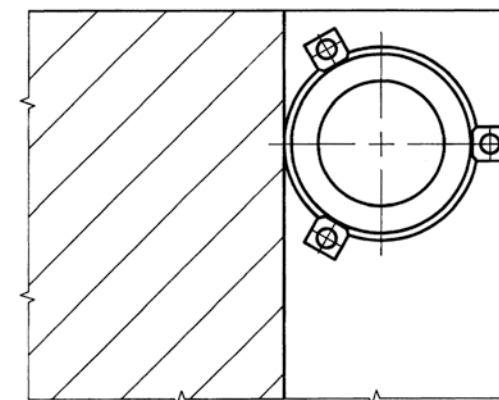

Position Z

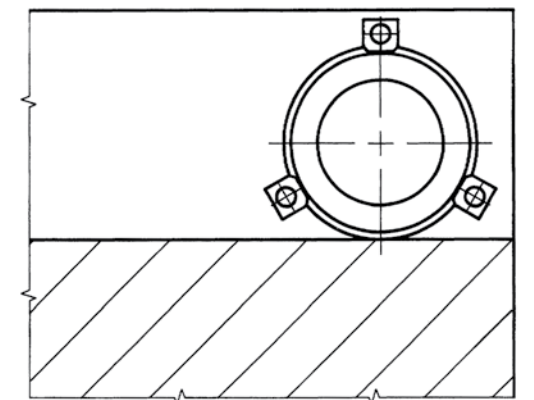

Position X

Haltescheiben für Bundsäulenbefestigung

Holding discs for mounting of leader pins with collar

FÜHRUNGSSYSTEME / GUIDINGSYSTEMS



FS 958

Mat.: C 40, brüniert
Scheibe wird mit Schraube befestigt

Mat.: C 40, gunmetal-finished
Mount disc with screw.

FS 958 / A

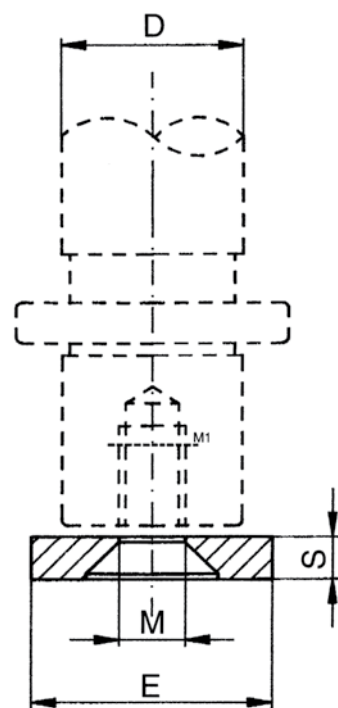

Ausführung Style	D	E	S	M
A	18-19	25	6	M8
B	24-25	32	7	M10
C	30-32	40	7	M10
D	40-42	50	9	M12
E	50-52	62	9	M12
F	63	73	9	M12
G	80	93	12	M12
H	100	120	20	M16

Gleitplatten VDI 3357, Bronze mit Festschmierstoff, 20 mm dick

Wear plates VDI 3357, bronze with self lubricating graphite plugs, 20 mm thick

FÜHRUNGSSYSTEME / GUIDINGSYSTEMS



FS 500

Mat.: Bronze

Mat.: Bronze

FS 500 / 50 x 100

Gleitplatten aus Bronze mit Festschmierstoff-Einsätzen gewährleisten auch im Dauerbetrieb einen wartungsarmen Einsatz.

Bronze wear plates with self lubricating graphite plugs ensure even during long-term production cycles a low maintenance operation.

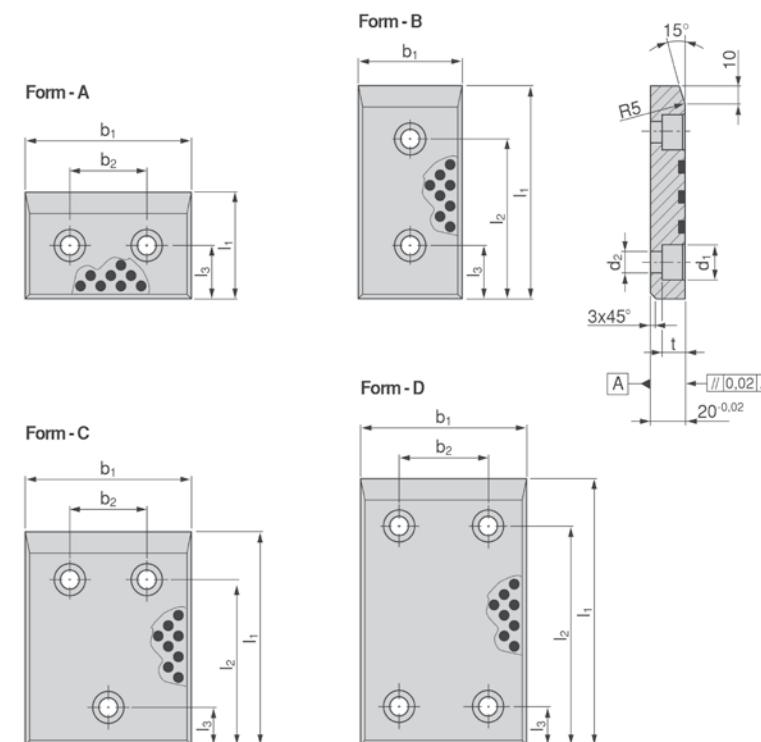

b1	l1	Form	b2	d1	d2	l2	l3	t	b1	l1	Form	b2	d1	d2	l2	l3	t
50	80	B	-	15	9	55	25	9	100	250	B	-	20	13,5	210	40	13
50	100	B	-	20	13,5	75	25	13	100	315	B	-	20	13,5	275	40	13
50	125	B	-	20	13,5	100	25	13	125	50	A	75	20	13,5	-	25	13
50	160	B	-	20	13,5	135	25	13	125	80	A	75	20	13,5	-	40	13
50	200	B	-	20	13,5	175	25	13	125	100	C	75	20	13,5	75	25	13
80	50	A	30	15	9	-	25	9	125	125	C	75	20	13,5	100	25	13
80	80	B	-	20	13,5	55	25	13	125	160	C	75	20	13,5	135	25	13
80	100	B	-	20	13,5	75	25	13	125	200	C	75	20	13,5	175	25	13
80	125	B	-	20	13,5	100	25	13	125	250	C	75	20	13,5	210	40	13
80	160	B	-	20	13,5	135	25	13	125	315	C	75	20	13,5	275	40	13
80	200	B	-	20	13,5	175	25	13	160	50	A	110	20	13,5	-	25	13
80	250	B	-	20	13,5	210	40	13	160	80	A	110	20	13,5	-	40	13
80	315	B	-	20	13,5	275	40	13	160	100	C	110	20	13,5	75	25	13
100	50	A	50	20	13,5	-	25	13	160	125	C	110	20	13,5	100	25	13
100	80	A	50	20	13,5	-	40	13	160	160	C	110	20	13,5	135	25	13
100	100	B	-	20	13,5	75	25	13	160	200	C	110	20	13,5	175	25	13
100	125	B	-	20	13,5	100	25	13	160	250	D	110	20	13,5	210	40	13
100	160	B	-	20	13,5	135	25	13	160	315	D	110	20	13,5	275	40	13
100	200	B	-	20	13,5	175	25	13									

FS 501

Mat.: 16MnCr5
Oberflächenhärte: 60 - 64 HRC

Mat.: 16MnCr5
Surface hardness: 60 - 64 HRC

FS 501 / 80 x 50

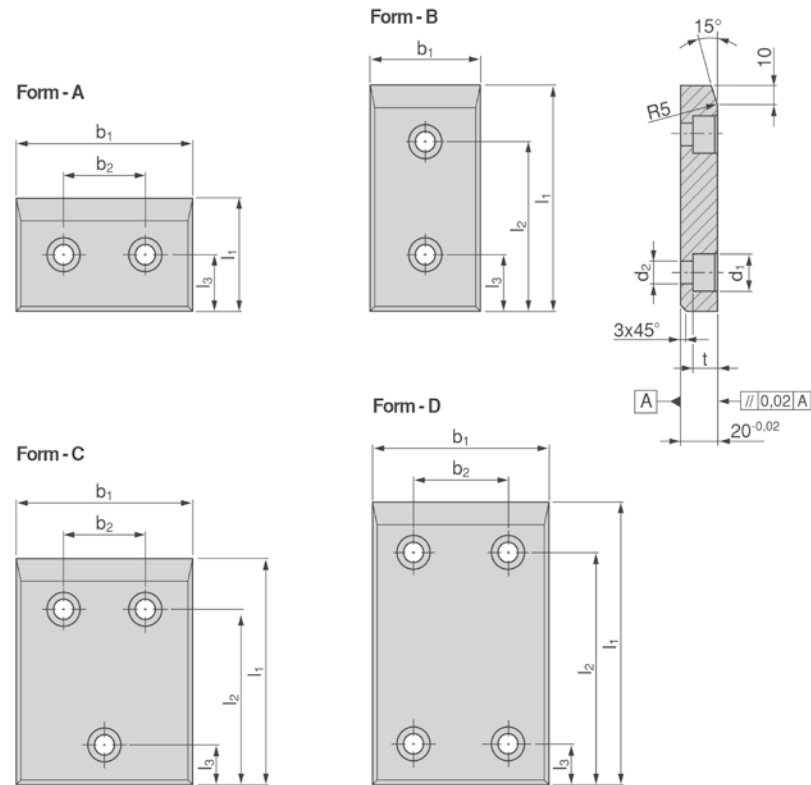

b1	l1	Form	b2	d1	d2	l2	l3	t
50	80	B	-	15	9	55	25	9
50	100	B	-	20	13,5	75	25	13
50	125	B	-	20	13,5	100	25	13
50	160	B	-	20	13,5	135	25	13
50	200	B	-	20	13,5	175	25	13
80	50	A	30	15	9	-	25	9
80	80	B	-	20	13,5	55	25	13
80	100	B	-	20	13,5	75	25	13
80	125	B	-	20	13,5	100	25	13
80	160	B	-	20	13,5	135	25	13
80	200	B	-	20	13,5	175	25	13
80	250	B	-	20	13,5	210	40	13
80	315	B	-	20	13,5	275	40	13
100	50	A	50	20	13,5	-	25	13
100	80	A	50	20	13,5	-	40	13
100	100	B	-	20	13,5	75	25	13
100	125	B	-	20	13,5	100	25	13
100	160	B	-	20	13,5	135	25	13
100	200	B	-	20	13,5	175	25	13

b1	l1	Form	b2	d1	d2	l2	l3	t
100	250	B	-	20	13,5	210	40	13
100	315	B	-	20	13,5	275	40	13
125	50	A	75	20	13,5	-	25	13
125	80	A	75	20	13,5	-	40	13
125	100	C	75	20	13,5	75	25	13
125	125	C	75	20	13,5	100	25	13
125	160	C	75	20	13,5	135	25	13
125	200	C	75	20	13,5	175	25	13
125	250	C	75	20	13,5	210	40	13
125	315	C	75	20	13,5	275	40	13
160	50	A	110	20	13,5	-	25	13
160	80	A	110	20	13,5	-	40	13
160	100	C	110	20	13,5	75	25	13
160	125	C	110	20	13,5	100	25	13
160	160	C	110	20	13,5	135	25	13
160	200	C	110	20	13,5	175	25	13
160	250	D	110	20	13,5	210	40	13
160	315	D	110	20	13,5	275	40	13

FS 502

Mat.: Bronze

Mat.: Bronze

FS 502 / 30 x 80

Gleitplatten aus Bronze mit Festschmierstoff-Einsätzen gewährleisten auch im Dauerbetrieb einen wartungsarmen Einsatz.

Bronze wear plates with self lubricating graphite plugs ensure even during long-term production cycles a low maintenance operation.

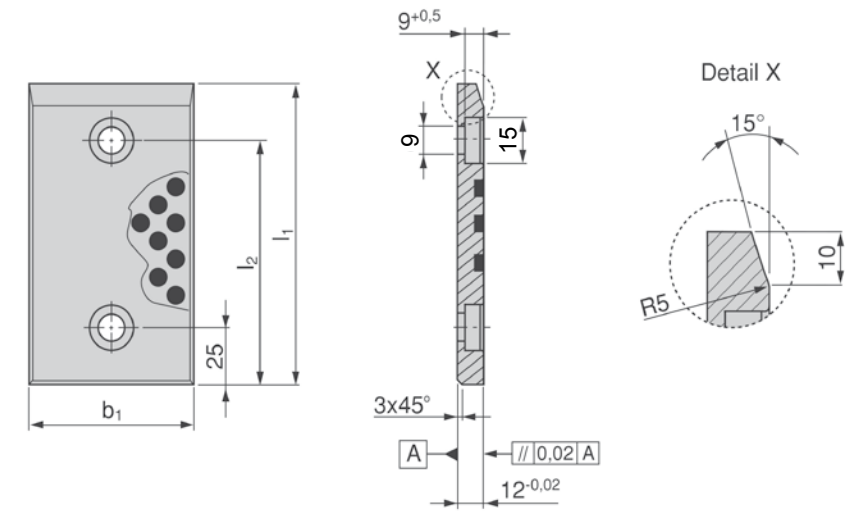

b1	l1	l2
30	80	55
30	100	75
30	125	100
30	160	135
30	200	175
40	80	55
40	100	75
40	125	100
40	160	135
40	200	175
50	80	55
50	100	75
50	125	100

b1	l1	l2
50	160	135
50	200	175
60	80	55
60	100	75
60	125	100
60	160	135
60	200	175
80	80	55
80	100	75
80	125	100
80	160	135
80	200	175

FS 503

Mat.: Bronze-Graphit

Mat.: Bronze-graphite

FS 503 / 18 x 125

Gleitplatten aus Bronze mit Festschmierstoff-Einsätzen gewährleisten auch im Dauerbetrieb einen wartungsarmen Einsatz.

Bronze wear plates with self lubricating graphite plugs ensure a low maintenance operation, even during long-term production cycles.

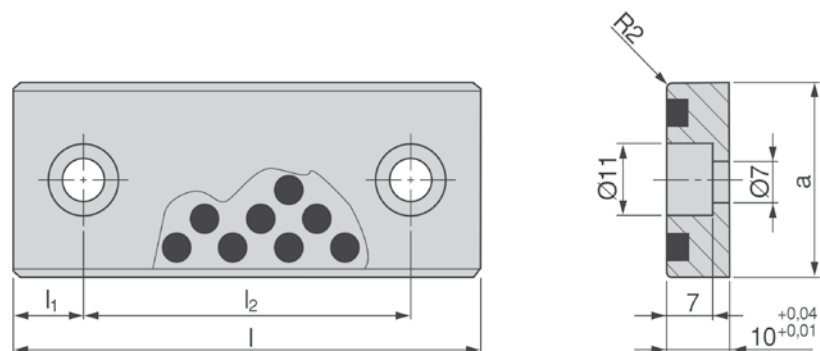

a	l	l1	l2
18	75	15	45
18	100	25	50
18	125	25	75
18	150	25	100
28	75	15	45
28	100	25	50
28	125	25	75
28	150	25	100
38	75	15	45
38	100	25	50
38	125	25	75
38	150	25	100
48	75	15	45
48	100	25	50
48	125	25	75
48	150	25	100



FS 504

Mat.: Bronze-Graphit

Mat.: Bronze-graphite

FS 504 / 48 x 150

Gleitplatten aus Bronze mit Festschmierstoff-Einsätzen gewährleisten auch im Dauerbetrieb einen wartungsarmen Einsatz.

Bronze wear plates with self lubricating graphite plugs ensure a low maintenance operation, even during long-term production cycles.

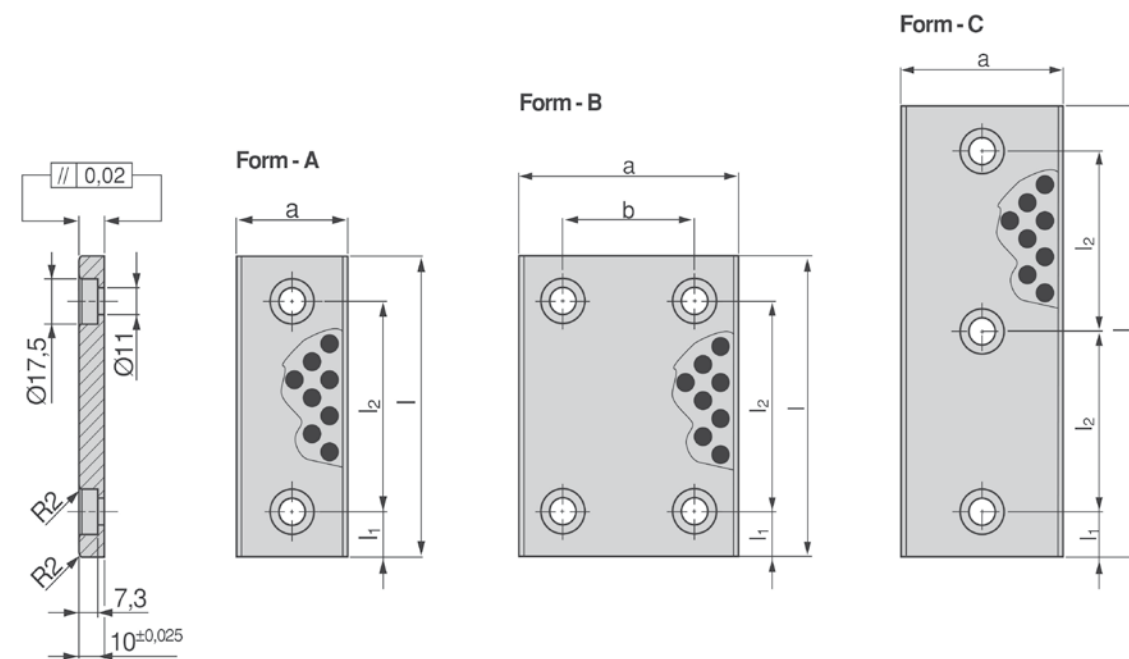

a	l	Form	b	l1	l2
28	75	A	-	15	45
28	100	A	-	25	50
28	125	A	-	25	75
28	150	A	-	25	100
38	75	A	-	15	45
38	100	A	-	25	50
38	125	A	-	25	75
38	150	A	-	25	100
48	75	A	-	15	45
48	100	A	-	25	50
48	125	A	-	25	75
48	150	A	-	25	100
48	200	A	-	50	100
58	75	A	-	15	45
58	100	A	-	25	50
58	125	A	-	25	75
58	150	A	-	25	100

a	l	Form	b	l1	l2
58	200	A	-	50	100
75	75	A	-	15	45
75	100	A	-	25	50
75	125	A	-	25	75
75	150	A	-	25	100
75	200	C	-	25	75
100	100	B	50	25	50
100	125	B	50	25	75
100	150	B	50	25	100
100	200	B	50	25	150
100	250	B	50	25	200
125	150	B	50	25	100
125	200	B	50	25	150
125	250	B	50	25	200
150	150	B	100	25	100
150	200	B	100	25	150



Gleitplatten, Bronze mit Festschmierstoff, 5 mm dick

Wear plates, bronze with self lubricating graphite plugs, 5 mm thick

FÜHRUNGSSYSTEME / GUIDINGSYSTEMS



FS 505

Mat.: Bronze-Graphit

Gleitplatten aus Bronze mit Festschmierstoff-Einsätzen gewährleisten auch im Dauerbetrieb einen wartungsarmen Einsatz.

Mat.: Bronze-graphite

Bronze wear plates with self lubricating graphite plugs ensure a low maintenance operation, even during long-term production cycles.

FS 505 / 75 x 75

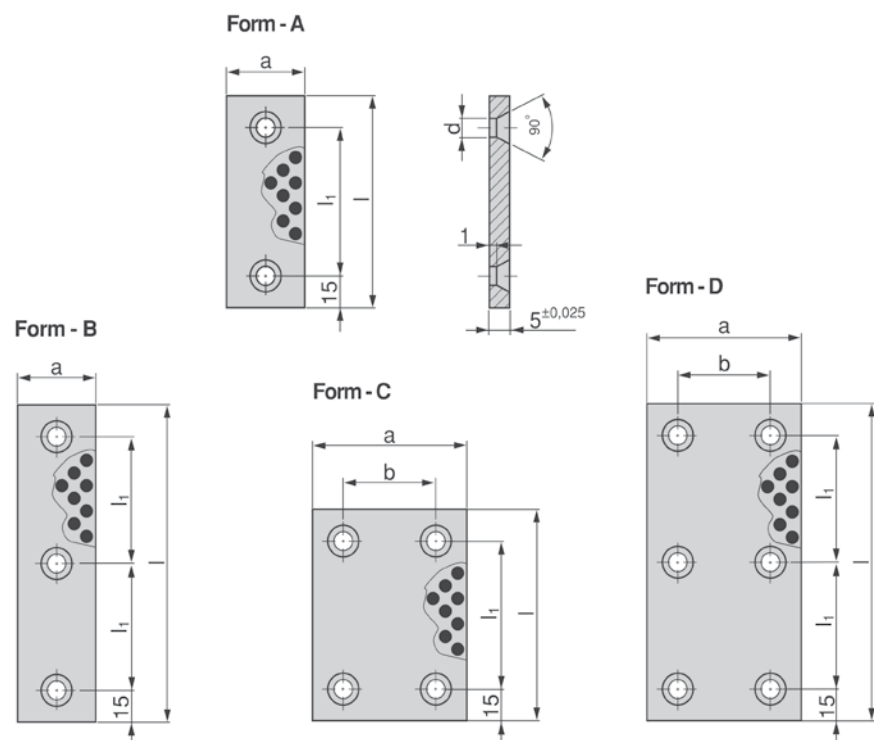

a	l	Form	b	d	l1
18	50	A	-	6,5	20
18	75	A	-	6,5	45
18	100	A	-	6,5	70
18	150	B	-	6,5	60
28	50	A	-	9	20
28	75	A	-	9	45
28	100	A	-	9	70
28	150	B	-	9	60
38	50	A	-	9	20
38	75	A	-	9	45
38	100	A	-	9	70
38	150	B	-	9	60
48	75	A	-	9	45
48	100	A	-	9	70
48	125	A	-	9	95
48	150	B	-	9	60
75	75	C	45	9	45
75	100	C	45	9	70
75	125	C	45	9	95
75	150	D	45	9	60
100	100	C	70	9	70
100	125	C	70	9	95
100	150	D	70	9	60

Gleitleisten VDI 3357, Bronze mit Festschmierstoff

Wear strips VDI 3357, bronze with self lubricating graphite plugs

FÜHRUNGSSYSTEME / GUIDINGSYSTEMS



FS 506

mit 2 Gleitflächen
Mat.: Bronze-Graphit

Gleitplatten aus Bronze mit Festschmierstoff-Einsätzen gewährleisten auch im Dauerbetrieb einen wartungsarmen Einsatz.

with 2 slide surfaces
Mat.: Bronze-graphite

Bronze wear plates with self lubricating graphite plugs ensure a low maintenance operation, even during long-term production cycles.

FS 506 / 15 x 110

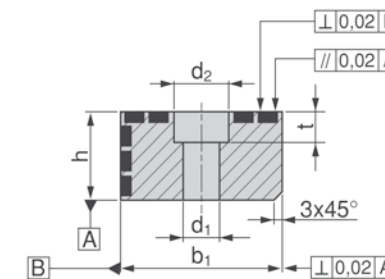

Form - A

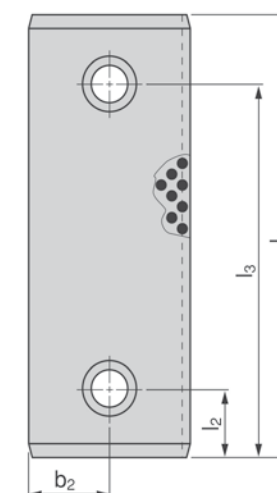

Form - B

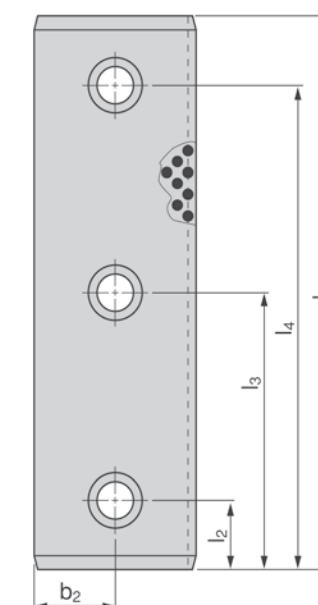

h	l1	Form	b1	b2	d1	d2	l2	l3	l4	t
-0,02	H7		-0,02		H13	H13		±0,2	±0,2	+0,5
12	110	A	25	12,5	9	15	25	85	-	8,5
12	120	A	25	12,5	9	15	25	95	-	8,5
15	110	A	25	12,5	11	18	25	85	-	10,5
15	120	A	25	12,5	11	18	25	95	-	10,5
30	125	A	60	30	13,5	20	25	100	-	13
30	160	A	60	30	13,5	20	25	135	-	13
30	200	B	60	30	13,5	20	25	100	175	13
40	125	A	60	30	13,5	20	25	100	-	13
40	160	A	60	30	13,5	20	25	135	-	13
40	200	B	60	30	13,5	20	25	100	175	13

Überlaufkeil VDI 3357, Bronze mit Festschmierstoff

Cam dwells VDI 3357, bronze with self lubricating graphite plugs

FÜHRUNGSSYSTEME / GUIDINGSYSTEMS



FS 507

mit 2 Gleitflächen
Mat.: Bronze-Graphit

with 2 slide surfaces
Mat.: Bronze-graphite

**FS 507 /
125 x 170 x 45**

Gleitplatten aus Bronze mit Festschmierstoff-Einsätzen gewährleisten auch im Dauerbetrieb einen wartungsarmen Einsatz.

Bronze wear plates with self lubricating graphite plugs ensure a low maintenance operation, even during long-term production cycles.

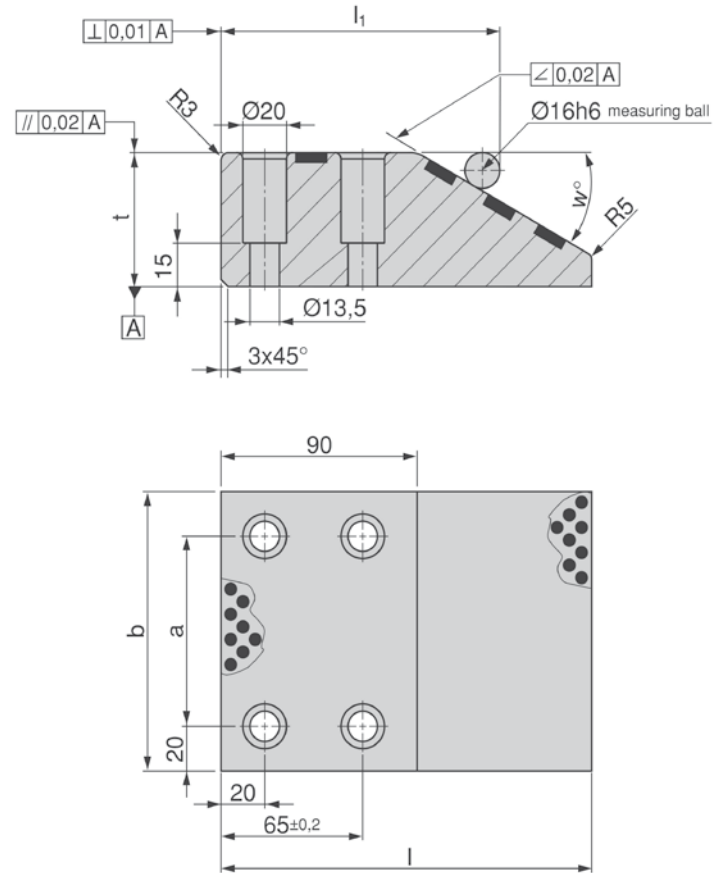

b	l	t ±0,1	a	l1 ±0,5	w
100	170	45	60	143,37	20°
125	170	45	85	143,37	20°
150	170	45	110	143,37	20°
100	150	45	60	127,86	30°
100	170	60	60	127,86	30°
125	150	45	85	127,86	30°
125	170	60	85	127,86	30°
150	150	45	110	127,86	30°
150	170	60	110	127,86	30°



[17.03.2022]
[17.03.2022]

Überlaufkeile VDI 3357, Stahl

Cam dwells VDI 3357, steel

FÜHRUNGSSYSTEME / GUIDINGSYSTEMS



FS 508

Mat.: X153CrMoV12
Oberflächenhärte: 60 - 62 HRC

Mat.: X153CrMoV12
Surface hardness: 60 - 62 HRC

**FS 508 /
125 x 170 x 45**

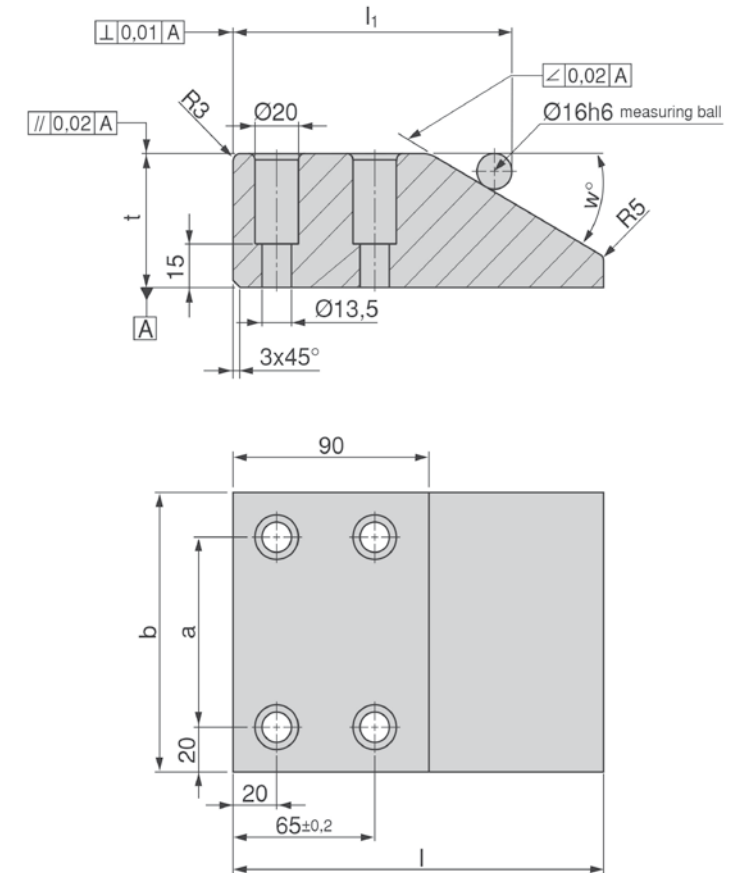

b	l	t ±0,1	a	l1 ±0,5	w
100	170	45	60	143,37	20°
125	170	45	85	143,37	20°
150	170	45	110	143,37	20°
100	150	45	60	127,86	30°
100	170	60	60	127,86	30°
125	150	45	85	127,86	30°
125	170	60	85	127,86	30°
150	150	45	110	127,86	30°
150	170	60	110	127,86	30°



FS 509

Mat.: CK45
Oberflächenhärte: 58 - 60 HRC

Mat.: CK45
Surface hardness: 58 - 60 HRC

**FS 509 /
63 x 180 x 36**

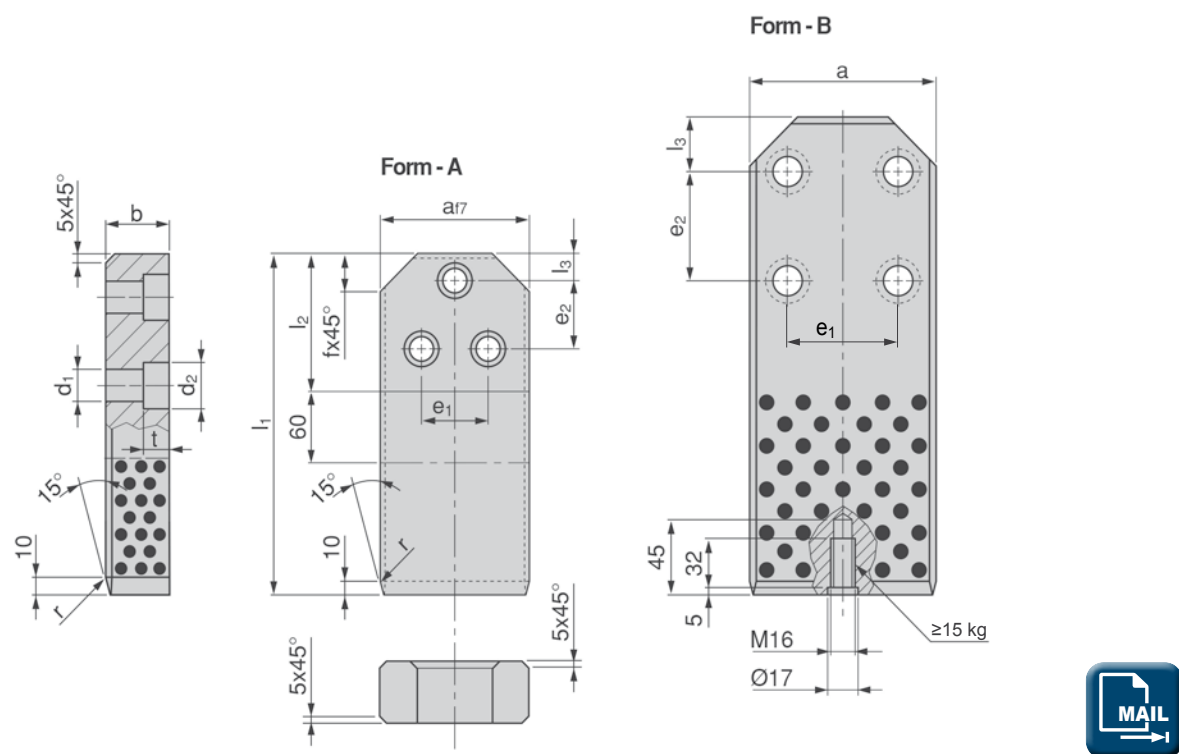

a	l1	b	l2	l3	e1	e2	d1	d2	t	f	r	Form
63	180	36	90	20	50	50	14	20	16	18	16	A
63	200	36	90	20	50	50	14	20	16	18	16	A
63	224	36	90	20	50	50	14	20	16	18	16	A
71	180	36	90	20	50	50	14	20	16	18	16	A
71	200	36	90	20	50	50	14	20	16	18	16	A
71	224	36	90	20	50	50	14	20	16	18	16	A
90	200	36	100	20	50	50	18	26	21	28	25	A
90	224	36	100	20	50	50	18	26	21	28	25	A
90	250	36	100	20	50	50	18	26	21	28	25	A
90	200	45	100	20	50	50	18	26	21	28	25	A
90	224	45	100	20	50	50	18	26	21	28	25	A
90	250	45	100	20	50	50	18	26	21	28	25	A
112	200	45	100	20	50	50	18	26	21	28	25	A
112	224	45	100	20	50	50	18	26	21	28	25	A
112	250	45	100	20	50	50	18	26	21	28	25	A
140	315	45	150	40	90	80	22	33	25,5	36	31,5	B
140	400	45	150	40	90	80	22	33	25,5	36	31,5	B
140	315	56	150	40	90	80	22	33	25,5	36	31,5	B
140	400	56	150	40	90	80	22	33	25,5	36	31,5	B
190	315	45	150	40	90	80	22	33	25,5	36	31,5	B
190	400	45	150	40	90	80	22	33	25,5	36	31,5	B
190	315	56	150	40	90	80	22	33	25,5	36	31,5	B
190	400	56	150	40	90	80	22	33	25,5	36	31,5	B
240	500	56	250	40	160	160	26	40	30,5	36	31,5	B
240	630	56	250	40	160	160	26	40	30,5	36	31,5	B

FS 510

Mat.: Bronze-Graphit

Mat.: Bronze-graphite

**FS 510 /
20 x 26 x 100**

Gleitplatten aus Bronze mit Festschmierstoff-Einsätzen gewährleisten auch im Dauerbetrieb einen wartungsarmen Einsatz.

Bronze wear plates with self lubricating graphite plugs ensure a low maintenance operation, even during long-term production cycles.

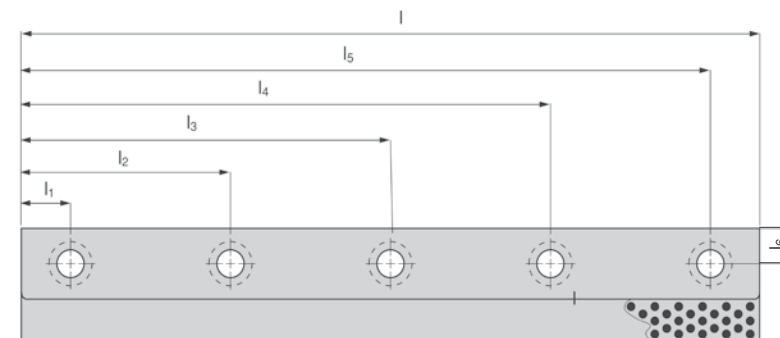
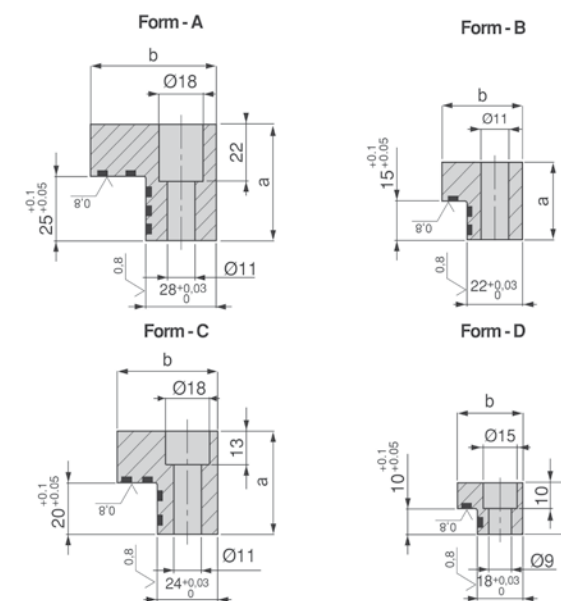

a	b	l	Form	l1	l2	l3	l4	l5	l6	Bohrungen Holes
±0,25	±0,25									
20	26	100	D	20	80	-	-	-	9	2
20	26	150	D	20	75	130	-	-	9	3
20	26	200	D	20	75	125	180	-	9	4
30	32	100	B	20	80	-	-	-	11	2
30	32	150	B	20	75	130	-	-	11	3
30	32	200	B	20	75	125	180	-	11	4
30	32	250	B	20	90	160	230	-	11	4
40	40	160	C	15	145	-	-	-	12	2
40	40	250	C	15	145	225	-	-	12	3
45	50	200	A	20	75	125	180	-	14	4
45	50	250	A	20	90	160	230	-	14	4
45	50	300	A	20	85	150	215	280	14	5
45	50	350	A	20	100	175	250	330	14	5

FS 511

Mat.: Bronze-Graphit

Gleitplatten aus Bronze mit Festschmierstoff-Einsätzen gewährleisten auch im Dauerbetrieb einen wartungsarmen Einsatz.

Mat.: Bronze-graphite

Bronze wear plates with self lubricating graphite plugs ensure a low maintenance operation, even during long-term production cycles.

FS 511 / 55 x 55 x 100

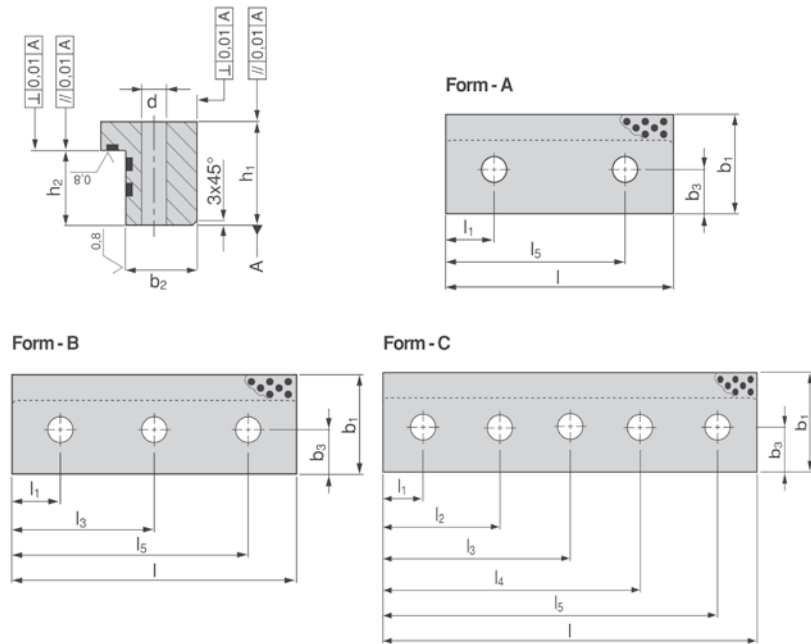

b1 ±0,2	h1 ±0,2	l -0,2	Form	b2 -0,02	b3 ±0,2	d H13	l1 ±0,2	l2 ±0,2	l3 ±0,2	l4 ±0,2	l5 ±0,2	h2 +0,02
55	55	100	A	37	20	13,5	27,5	-	-	-	72,5	39
55	55	160	A	37	20	13,5	27,5	-	-	-	132,5	39
70	75	160	A	50	30	17,5	35	-	-	-	125	55
70	75	200	A	50	30	17,5	35	-	-	-	165	55
70	75	250	B	50	30	17,5	35	-	125	-	215	55
70	75	400	C	50	30	17,5	35	125	200	275	365	55
85	90	160	A	63	38	22	42,5	-	-	-	117,5	65
85	90	200	A	63	38	22	42,5	-	-	-	157,5	65
85	90	250	B	63	38	22	42,5	-	125	-	207,5	65
85	90	400	C	63	38	22	42,5	125	200	275	357,5	65



FS 524

Mat.: CK45
Oberflächenhärte: 56 - 60 HRC

Mat.: CK45
Surface hardness: 56 - 60 HRC

FS 524 / 65 x 150

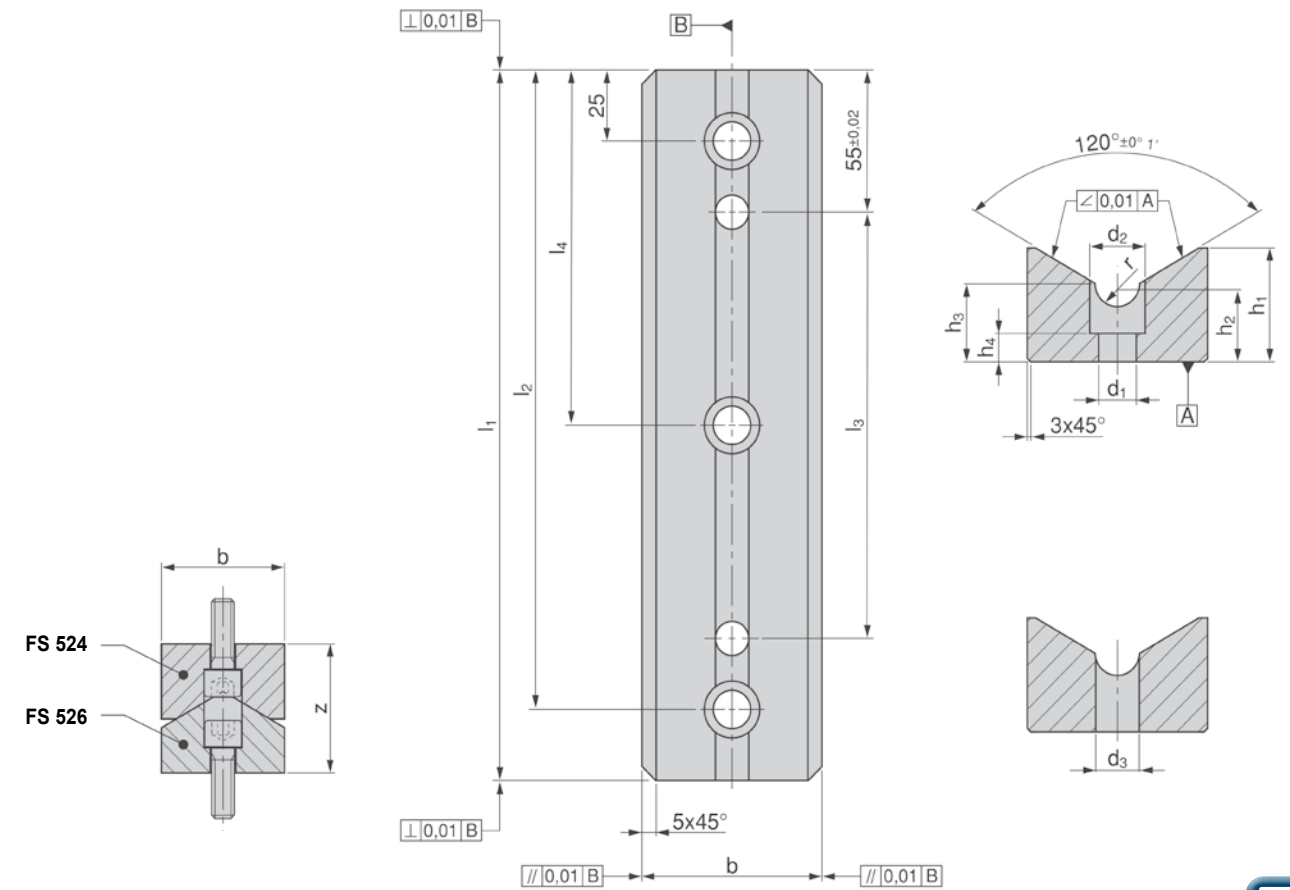

b h6	l1 -0,2	d1 H13	d2 H13	d3 H7	h1 ±0,2	h2 ±0,01	h3 ±0,2	h4	l2 ±0,2	l3 ±0,01	l4 ±0,2	r	z +0,05
65	150	13,5	20	12	35	18	22	8	125	45	-	7	65
65	200	13,5	20	12	35	18	22	8	175	95	-	7	65
65	250	13,5	20	12	35	18	22	8	225	145	125	7	65
65	300	13,5	20	12	35	18	22	8	275	195	150	7	65
125	150	17,5	26	16	60	28	34	15	125	45	-	10	85
125	200	17,5	26	16	60	28	34	15	175	95	-	10	85
125	250	17,5	26	16	60	28	34	15	225	145	125	10	85
125	300	17,5	26	16	60	28	34	15	275	195	150	10	85



FS 526

Mat.: Bronze-Graphit

Mat.: Bronze-graphite

FS 526 / 65 x 150

Gleitplatten aus Bronze mit Festschmierstoff-Einsätzen gewährleisten auch im Dauerbetrieb einen wartungsarmen Einsatz.

Bronze wear plates with self lubricating graphite plugs ensure a low maintenance operation, even during long-term production cycles.

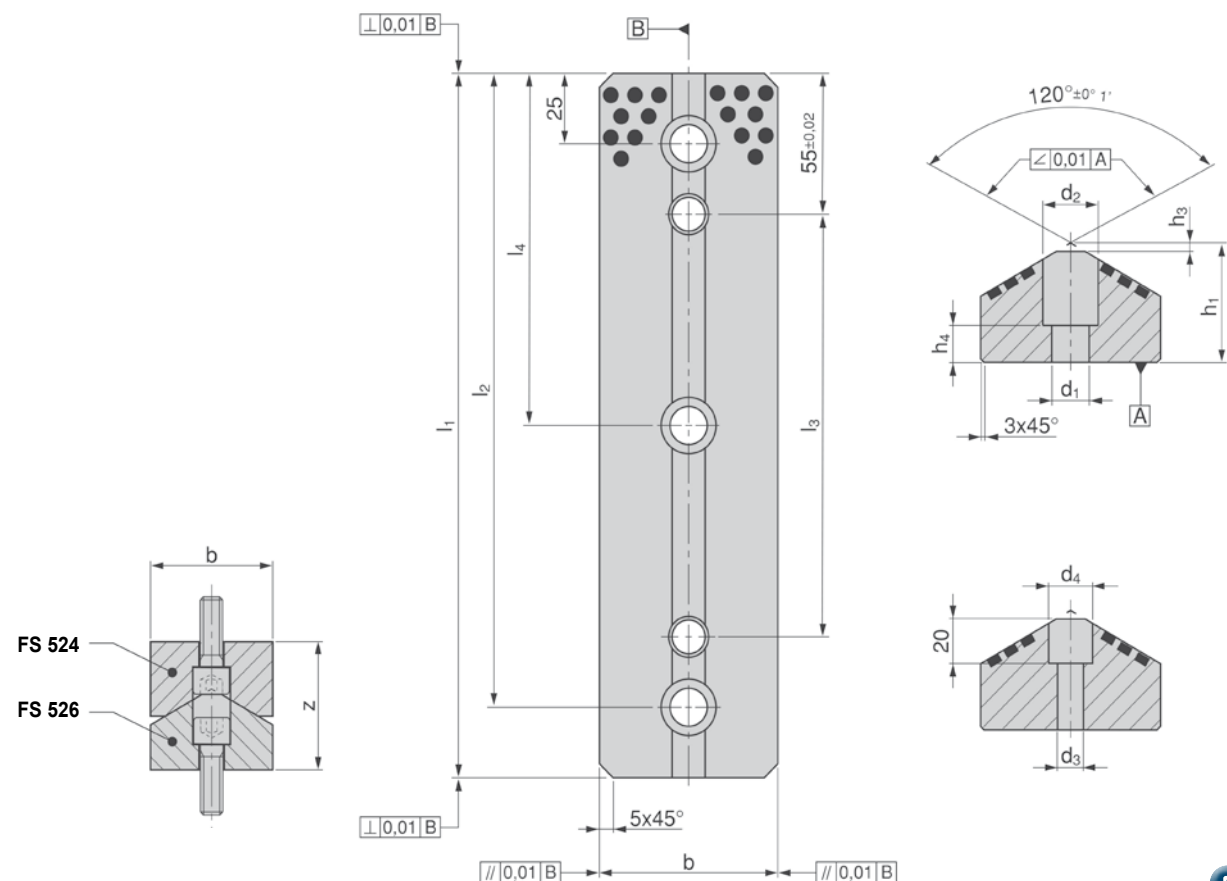

b	l1	d1	d2	d3	d4	h1	h3	l2	l3	l4	z
h6	-0,2	H13	H13	H7	H13	±0,01		±0,2	±0,01	±0,2	+0,05
65	150	13,5	20	12	14	47	3	125	45	-	65
65	200	13,5	20	12	14	47	3	175	95	-	65
65	250	13,5	20	12	14	47	3	225	145	125	65
65	300	13,5	20	12	14	47	3	275	195	150	65
125	150	17,5	26	16	18	57	5	125	45	-	85
125	200	17,5	26	16	18	57	5	175	95	-	85
125	250	17,5	26	16	18	57	5	225	145	125	85
125	300	17,5	26	16	18	57	5	275	195	150	85



FS 410
FS 412

Technischer Hinweis:
Säulen-Aufnahmebohrungen: H7
Säulentyp **FS 410** kann ab ø80 mm mit 2 Transportgewinden M12 geliefert werden (bitte angeben).
Säulentyp **FS 412** bis ø63 mm ohne Hohlbohrung, ab ø80 mm mit Hohlbohrung und 2 Transportgewinden M12 (bitte angeben).
Passende Führungsbuchsen finden Sie auf Seite FS.34

Technical recommendation:
Leader pin mounting holes: H7
Leader pin type **FS 410** with 80 mm diameter and larger can be supplied with two transport-threads M12 (please specify when ordering).
Leader pin type **FS 412** up to 63 mm without internal hole, 80 mm diameter and larger with internal hole and with two transport-threads M12 (please specify when ordering).

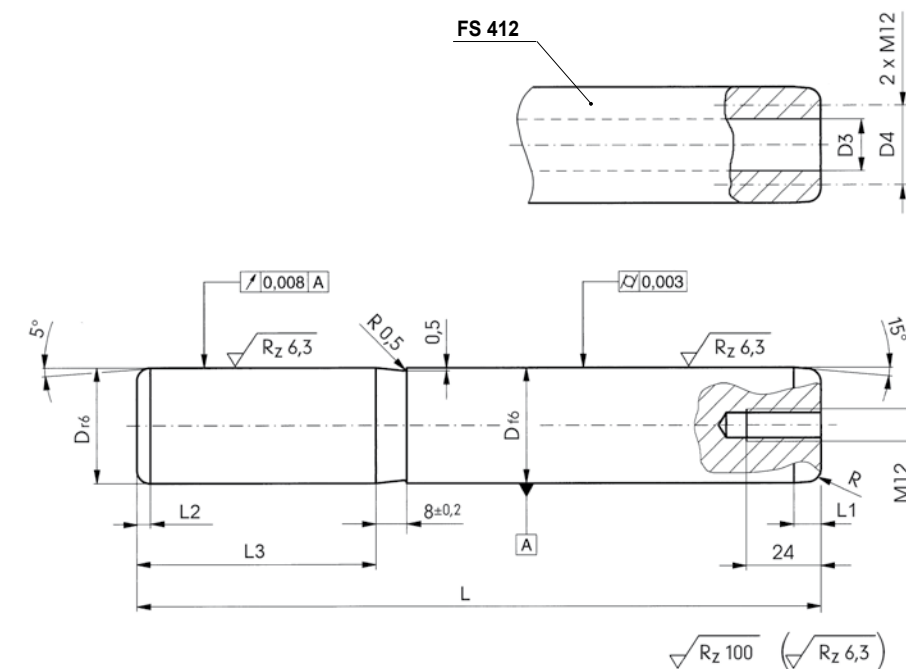



FS 330 ... RM
FS 340 ... RM
FS 350 ... RM
FS 430 ... RM
FS 439 ... RM
FS 440 ... RM
FS 450 ... RM

Bei RM-Coat handelt es sich um eine dunkelblaugraue Gleitstoffbeschichtung auf Basis Wolframdisulfid (WS2) mit einer Stärke von 0,0005 - 0,0015 mm, die bei Raumtemperatur aufgebracht wird und bis 650 °C stabil bleibt.

Sie reduziert - abhängig vom spezifischen Anwendungsfall - die Reibung um bis zu 70%, was zu einer signifikanten Verbesserung der Schmier- und Gleiteigenschaften der beschichteten Teile führt. Außer einer leichten anfänglichen Schmierung und bei den üblichen Wartungen kann der Schmiermittel-Einsatz in vielen Fällen reduziert werden, wobei meist zusätzlich noch eine deutliche Verlängerung der Standzeiten zu verzeichnen ist.

Sie kann nicht nur, aber auch, auf andere Beschichtungen - wie z.B. PVD und CVD - zusätzlich aufgetragen werden.

Typische Anwendungsbeispiele finden sich beim Umformen, in Wälz- und Gleitlagern und in der Vakuumtechnik. Erstklassige Resultate werden auch im gesamten Bereich der Spritzgießtechnik erzielt, angefangen bei den Führungselementen bis hin zur Beschichtung von komplexen, schwer entformbaren Konturkernen.

Um eine bestmögliche Verbindung zum Trägermaterial zu gewährleisten, müssen die zu beschichtenden Teile vollständig (von Ölen / Fetten, Staub u.ä.) gesäubert werden.

Die Beschichtung lässt sich nur durch mechanische Bearbeitung wieder entfernen.

Die Technik der Wolframdisulfid-Beschichtung findet sich in jedem amerikanischen Flugzeug. Sie ist unter den strengen Auflagen der amerikanischen NAMS - Class 6 getestet und als bio-kompatibel eingestuft worden. Der Beschichtungs-Prozess wird in Übereinstimmung mit den US-Militär - Spezifikationen DOD-L-85645 A Type 1 ausgeführt.

Im Programm der Märkischen Stanz-Partner werden die Artikel der Serie **FS 330 / ... bis FS 350 / ...** standardmäßig mit RM-Coat beschichtet, bei allen anderen Führungs- und Funktionsteilen nach Rücksprache bzw. nach Anforderung.

Bezüglich weiterer Anwendungsfälle sprechen Sie uns gerne an.

RM-Coat is a dark blue / grey tungsten disulfid (WS2) lubricant coating, being applied at room temperature with a thickness of 0,0005 - 0,0015 mm. It is stable up to 650 degrees Celsius.

Depending on the specific application, this coating reduces friction up to 70%, leading to significantly improved sliding-characteristics of the coated parts. After a slight initial lubrication (and during the usually scheduled maintenance works), in a lot of cases the lubricant can be reduced and minimized ... while at the same time in most cases the tool-life considerably extends.

The RM Coat can (not must!) be applied on other coatings like PVD and CVD as well.

Typical applications can be found in sheet metal forming processes, roller- and plain bearings and in vacuum technologies. Top results have been accomplished in injection molding as well, by coating not only guiding elements, but complex, hard-to-stripp-off cores.

To provide for an excellent connection between the coating and the carrying material, the part to be coated has to be cleaned completely from dust, oil, grease etc.

The coating can only be removed mechanically.

The WS2-coating-technique can be found on every American airplane. Metercoat has been NAMS - Class 6 tested and certified as bio-compatible. The whole coating process is carried out in compliance with DOD-L-85645 A Type 1.

In our program the products from **FS 330 / ... to FS 350 / ...** and **FS 430 / ... to FS 450 / ...** are RM-coated as standards, all other (guiding- and other) products can be treated upon request.

Please contact us with your specific application.